

ABRASIVES



PAGE

Brushes	300-304
Cartridge Rolls	338-339
Cut-Off Wheels	325-326
Depressed Center Wheels	328-329
Diamond Blades	327
Diamond Tools & Wheels	320-324
Flap Discs	330-331
Flap Wheels	335
Grinding Wheels	305-317
Honing Tools	299
Mounted Points	318-319
Non-Woven	340-343
PSA Discs	333
Quick Change Discs	331, 334
Resin Fibre Discs	332
Shop Rolls & Sheets	336-337

Flex-Hone® Tools

- Use on valve guides, cam bearing bores, main bearing bores, lifter bores, pneumatic cylinders, engine cylinders, brake cylinders, drums and rotors, hydraulic guides, pumps, and compressors.

• The Flex-Hone® Tool is resilient, flexible honing tool with soft cutting action. It's unique construction allows the abrasive globules or "stones" to float, assuring the tool will be self-centering, self-aligning to the bore and self-compensating for wear.

- The Flex-Hone® Tool removes peaks and other imperfections in cylinder walls, creating a desirable plateaued finish. The result is reduction in localized heat and friction and improved performance.

Standard Duty Flex-Hones®

- 4mm – 3/16" are 6" OAL
- 5mm – 3" are 8" OAL
- 3-1/4" – 4-5/8" are 13-1/2"

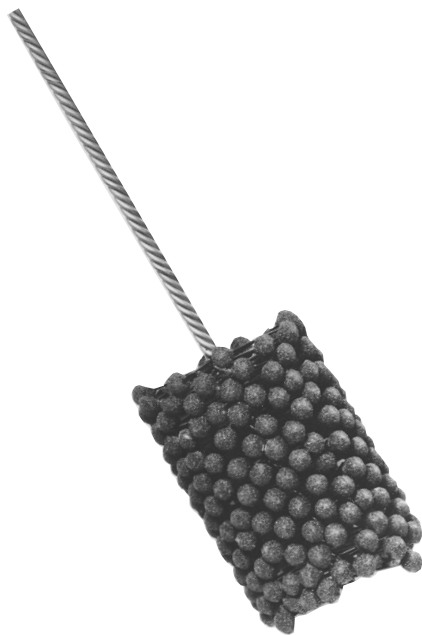
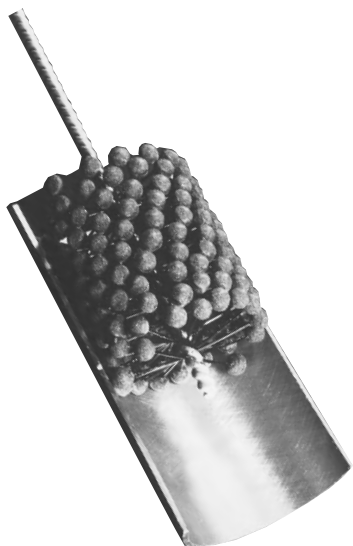

Silicon Carbide

FLEX-HONE MODEL NO.	BORE SIZE	120 GRIT		180 GRIT		240 GRIT		320 GRIT	
		ORDER NO.	PRICE EACH	ORDER NO.	PRICE EACH	ORDER NO.	PRICE EACH	ORDER NO.	PRICE EACH
BC-4MM	(0.157)	-	-	5690-151	\$16.90	5690-152	\$17.90	5690-153	\$25.30
BC-4.5MM	(0.177)	-	-	5690-171	16.60	5690-172	17.60	5690-173	24.90
BC-3/16"	(4.75MM)	-	-	5690-181	16.30	5690-182	17.30	5690-183	24.50
BC-5MM	(0.197)	5690-190	\$15.80	5690-191	15.80	5690-192	16.80	5690-193	23.70
BC-5.5MM	(0.217)	5690-210	16.10	5690-211	16.10	5690-212	17.10	5690-213	24.10
BC-6.4MM	(0.25)	5690-250	10.60	5690-251	10.60	5690-252	11.20	5690-253	15.90
BC-7MM	(0.276)	5690-270	10.70	5690-271	10.70	5690-272	11.30	5690-273	16.00
BC-8MM	(0.315)	5690-310	11.20	5690-311	11.20	5690-312	11.90	5690-313	16.80
BC-9MM	(0.354)	5690-350	11.70	5690-351	11.70	5690-352	12.40	5690-353	17.50
BC-9.5MM	(0.375)	5690-370	12.40	5690-371	12.40	5690-372	13.10	5690-373	18.60
BC-10MM	(0.394)	5690-390	12.50	5690-391	12.50	5690-392	13.30	5690-393	18.80
BC-11MM	(0.433)	5690-430	12.80	5690-431	12.80	5690-432	13.60	5690-433	19.20
BC-12MM	(0.472)	5690-470	13.10	5690-471	13.10	5690-472	13.90	5690-473	19.60
BC-1/2"	(12.7MM)	5690-500	13.30	5690-501	13.30	5690-502	14.10	5690-503	19.90
BC-14MM	(0.552)	5690-550	13.40	5690-551	13.40	5690-552	14.20	5690-553	20.10
BC-5/8"	(16MM)	5690-620	14.10	5690-621	14.10	5690-622	15.00	5690-623	21.20
BC-18MM	(0.709)	5690-700	14.50	5690-701	14.50	5690-702	15.40	5690-703	21.80
BC-3/4"	(19MM)	5690-750	14.90	5690-751	14.90	5690-752	15.80	5690-753	22.30
BC-20MM	(0.787)	5690-780	15.00	5690-781	15.00	5690-782	15.80	5690-783	22.40
BC-7/8"	(22MM)	5690-870	15.00	5690-871	15.00	5690-872	15.90	5690-873	22.60
BC-15/16"	(23.8MM)	5690-930	15.60	5690-931	15.60	5690-932	16.50	5690-933	23.30
BC-1"	(25.4MM)	5691-000	16.00	5691-001	16.00	5691-002	17.00	5691-003	24.10
BC-1-1/8"	(29MM)	5691-120	16.90	5691-121	16.90	5691-122	17.90	5691-123	25.30
BC-1-1/4"	(31.8MM)	5691-250	18.20	5691-251	18.20	5691-252	19.30	5691-253	27.30
BC1-3/8"	(35MM)	5691-370	18.70	5691-371	18.70	5691-372	19.80	5691-373	28.10
BC-1-1/2"	(38MM)	5691-500	20.10	5691-501	20.10	5691-502	21.30	5691-503	30.10
BC-1-5/8"	(41MM)	5691-620	20.10	5691-621	20.10	5691-622	21.30	5691-623	30.10
BC-1-3/4"	(45MM)	5691-750	21.00	5691-751	21.00	5691-752	22.20	5691-753	31.50
BC-1-7/8"	(48MM)	5691-870	21.40	5691-871	21.40	5691-872	22.70	5691-873	32.10
BC-2"	(51MM)	5692-000	21.70	5692-001	21.70	5692-002	23.10	5692-003	32.70
BC-2-1/8"	(54MM)	5692-120	22.70	5692-121	22.70	5692-122	24.00	5692-123	34.00
BC-2-1/4"	(57MM)	5692-250	23.60	5692-251	23.60	5692-252	25.00	5692-253	35.30
BC-2-3/8"	(60MM)	5692-370	24.50	5692-371	24.50	5692-372	25.90	5692-373	36.70
BC-2-1/2"	(64MM)	5692-500	25.40	5692-501	25.40	5692-502	26.90	5692-503	38.00
BC-2-5/8"	(67MM)	5692-620	26.70	5692-621	26.70	5692-622	28.30	5692-623	40.10
BC-2-3/4"	(70MM)	5692-750	28.00	5692-751	28.00	5692-752	29.70	5692-753	42.00
BC-2-7/8"	(73MM)	5692-870	30.30	5692-871	30.30	5692-872	32.10	5692-873	45.40
BC-3"	(76MM)	5693-000	32.50	5693-001	32.50	5693-002	34.50	5693-003	48.80
GB-3-1/4"	(83MM)	5693-100	36.70	5693-101	36.70	5693-102	38.90	5693-103	55.00
GB-3-1/2"	(89MM)	5693-120	39.10	5693-121	39.10	5693-122	41.40	5693-123	58.70
GB-3-3/4"	(95MM)	5693-140	42.10	5693-141	42.10	5693-142	44.60	5693-143	63.20
GB-4-1/8"	(105MM)	5693-160	44.80	5693-161	44.80	5693-162	47.50	5693-163	67.20
GB-4-5/8"	(118MM)	5693-180	49.90	5693-181	49.90	5693-182	52.90	5693-183	74.90

FLEX-HONE MODEL NO.	BORE SIZE	120 GRIT		180 GRIT		240 GRIT		320 GRIT	
		ORDER NO.	PRICE EACH	ORDER NO.	PRICE EACH	ORDER NO.	PRICE EACH	ORDER NO.	PRICE EACH
GBD-3"	(76MM)	5693-300	\$53.20	5693-301	\$ 53.20	5693-302	\$ 56.40	5693-303	\$ 79.80
GBD-3-1/4"	(83MM)	5693-320	54.90	5693-321	54.90	5693-322	58.20	5693-323	82.30
GBD-3-1/2"	(89MM)	5693-340	56.50	5693-341	56.50	5693-342	59.90	5693-343	84.80
GBD-3-3/4"	(95MM)	5693-360	60.60	5693-361	60.60	5693-362	64.20	5693-363	90.90
GBD-4"	(101MM)	5693-380	64.70	5693-381	64.70	5693-382	68.60	5693-383	97.00
GBD-4-1/4"	(108MM)	5693-400	69.10	5693-401	69.10	5693-402	73.30	5693-403	103.20
GBD-4-1/2"	(114MM)	5693-420	73.60	5693-421	73.60	5693-422	78.00	5693-423	110.40
GBD-5"	(127MM)	5693-440	83.70	5693-441	83.70	5693-442	88.80	5693-443	125.60
GBD-5-1/2"	(140MM)	5693-460	91.80	5693-461	91.80	5693-462	97.30	5693-463	137.80
GBD-6"	(152MM)	5693-480	99.50	5693-481	99.50	5693-482	105.50	5693-483	149.30
GBD-6-1/2"	(165MM)	5693-500	107.20	5693-501	107.20	5693-502	113.70	5693-503	160.90
GBD-7"	(178MM)	5693-520	116.90	5693-521	116.90	5693-522	123.90	5693-523	175.40
GBD-7-1/2"	(190MM)	5693-540	128.60	5693-541	128.60	5693-542	136.30	5693-543	192.90
GBD-8"	(203MM)	5693-560	140.60	5693-561	140.60	5693-562	149.00	5693-563	210.90

Heavy Duty Flex-Hones®

- 3" – 4-1/2" are 13-1/2" OAL
- 5" – 8" are 17-1/2" OAL

Trulock Crimped Wire Wheel Brushes



Orbitor Bench Grinder Brushes



Features plastic snap-out arbor hole adapter.
Other arbor hole available on request

DIA.	WIRE SIZE	ARBOR HOLE	TRIM LENGTH	FACE WIDTH	MAX SAFE FREE SPEED (RPM)	STD. PKG.	ITEM NO.	PRICE EACH
Narrow Face								
4	.008	1/2-3/8†	7/8	1/2	6,000	2	6500-104	\$30.15
4	.0095	1/2-3/8†	7/8	1/2	6,000	2	6500-124	16.52
6	.008	5/8-1/2†	1-7/16	3/4	6,000	10	6501-045	24.81
6	.014	5/8-1/2†	1-7/16	3/4	6,000	10	6501-075	18.08
8	.0118	5/8-1/2†	2-1/16	3/4	6,000	2	6501-165	28.49
8	.014	5/8-1/2†	2-1/16	1/2	6,000	2	6501-175	25.18
10	.0118	3/4	2-1/2	3/4	4,000	2	6501-248	37.50
10	.014	3/4	2-1/2	3/4	4,000	2	6501-258	36.02
Medium Face								
6	.0118	2††	1-1/8	1	6,000	1	6506-070	34.76
6	.014	2††	1-1/8	1	6,000	1	6506-080	35.09
8	.0118	2††	1-3/8	1	4,000	1	6506-110	52.77
8	.014	2††	1-3/8	1	4,000	1	6506-120	52.50
10	.0118	2*	2	1-1/8	3,600	1	6506-150	86.73
10	.014	2**	2	1-1/8	3,600	1	6506-160	85.26
Wide Face								
6	.0118	2††	1-1/8	1-1/8	6,000	1	6503-060	53.13
8	.0118	2††	1-3/8	1-3/8	4,000	1	6503-140	81.95
10	.0118	2††	1-7/8	1-5/8	4,000	1	6503-190	143.75

DIA.	WIRE SIZE	ARBOR HOLE	TRIM LENGTH	FACE WIDTH	MAX SAFE FREE SPEED (RPM)	STD. PKG.	ITEM NO.	PRICE EACH
Narrow Face								
6	.014	5/8-1/2	1-1/16	5/8	6,000	1	6502-325	\$21.07
7	.014	5/8-1/2	1-9/16	3/4	6,000	1	6502-335	25.93
Medium Face								
6	.014	5/8-1/2	1-1/8	7/8	6,000	1	6506-645	26.18
7	.014	5/8-1/2	1-5/8	7/8	6,000	1	6506-655	30.53

Copper Center Wire Wheel Wire Fill

DIA.	WIRE SIZE	ARBOR HOLE	TRIM LENGTH	FACE WIDTH	MAX SAFE FREE SPEED (RPM)	STD. PKG.	ITEM NO.	PRICE EACH
2	.006	1/2	1/2	3/8	20,000	10	6515-433	\$6.99
2	.014	1/2-3/8	1/2	3/8	20,000	10	6515-473	5.15
3	.006	5/8	15/16	1/2	20,000	10	6515-637	10.13
3	.014	1/2	1	1/2	20,000	10	6515-553	7.04
3	.014	1/2-3/8	1	1/2	20,000	10	6515-573	6.16

Metal Adapters For Wire Wheel Brushes
(Used in pairs)

ADAPTER ARBOR SIZE	STD. PKG.	ORDER SIZE	PRICE EACH
1/2	1 Pr.	6503-809	\$1.64
5/8	1 Pr.	6503-810	1.64
3/4	1 Pr.	6503-811	1.64
7/8	1 Pr.	6503-824	1.64
1	1 Pr.	6503-812	1.64
1-1/4	1 Pr.	6503-813	1.64
1-1/2	1 Pr.	6503-814	1.97

† Features plastic snap-out arbor hole adapter
†† Other arbor holes available using metal adapter. Please specify.
* 1/2 x 1/4 Double keyway and uses metal adapter.

Dualife Knot Type Wire Wheel Brushes



Standard Twist Stainless Steel

DIA.	WIRE SIZE	ARBOR HOLE	TRIM LENGTH	FACE WIDTH	MAX SAFE FREE SPEED (RPM)	STD. PKG.	ITEM NO.	PRICE EACH
4	.020	1/2-3/8	7/8	1/2	20,000	10	6508-314	\$35.55
6	.016	5/8-1/2	1-3/8	1/2	9,000	2	6508-345	64.95
8	.016	5/8-1/2	1-5/8	5/8	6,000	2	6508-395	96.39

Standard Twist—Wide Face (Double Sections)

DIA.	WIRE SIZE	ARBOR HOLE	TRIM LENGTH	FACE WIDTH	MAX SAFE FREE SPEED (RPM)	STD. PKG.	ITEM NO.	PRICE EACH
6	.016	2	1-3/8	7/8	9,000	5	6509-180	\$64.96
8	.016	2	1-5/8	1	6,000	1	6509-430	94.49
10	.016	2	1-3/4	1-1/4	4,500	1	6509-480	126.13
12	.014	2	2-3/4	1-1/4	3,600	1	6509-530	164.61

Other arbor holes available using metal adapter

Standard Twist

DIA.	WIRE SIZE	ARBOR HOLE	TRIM LENGTH	FACE WIDTH	MAX SAFE FREE SPEED (RPM)	STD. PKG.	ITEM NO.	PRICE EACH
4	.014	1/2-3/8†	7/8	1/2	20,000	10	6508-044	\$18.71
4	.020	1/2-3/8†	7/8	1/2	20,000	10	6508-064	18.49
6	.016	5/8-1/2†	1-3/8	1/2	9,000	10	6508-095	28.65
8	.016	5/8-1/2†	1-5/8	5/8	6,000	2	6508-145	43.09
8	.023	5/8-1/2†	1-5/8	5/8	6,000	2	6508-155	41.86
10	.016	1-1/4*	1-3/4	3/4	4,500	2	6508-189	61.13
12	.014	1-1/4*	2-3/4	3/4	3,600	1	6508-209	79.29
12	.020	1-1/4*	2-1/4	5/8	5,000	2	6509-719	101.58
15	.016	1-1/4*	4-1/4	7/8	3,600	2	6508-249	102.20

† Features plastic snap-out arbor hole adapter
* 5/16 x 5/32 Double Keyway
Other diameters, arbor hole, or wire sizes available on request.



Cup Brushes



Knot Type - Single Row



Knot Type Double Row



Crimped Wire

DIA.	WIRE SIZE	ARBOR HOLE	TRIM LENGTH	MAX SAFE FREE SPEED (RPM)	STD. PKG.	ITEM NO.	PRICE EACH
Knot Type – Single Row							
4	.014	5/8-11	1-1/4	9,000	1	6512-306	\$30.67
4	.023	5/8-11	1-1/4	9,000	1	6512-316	27.83
4	.035	5/8-11	1-1/4	9,000	1	6512-326	27.91
6	.014	5/8-11	1-1/2	6,600	1	6512-356	59.66
6	.023	5/8-11	1-1/2	6,600	1	6512-376	55.93
6	.035	5/8-11	1-1/2	6,600	1	6512-396	54.92
Knot Type – Double Row – Heavy Duty							
6	.023	5/8-11	1-3/8	6,600	1	6512-556	77.91
Crimped Wire Medium & Light Duty Applications							
4	.014	5/8-11	1-3/8	9,000	1	6514-026	25.18
4	.020	5/8-11	1-3/8	9,000	1	6514-036	23.63
6	.014	5/8-11	1-1/4	6,600	1	6514-066	42.88
6	.020	5/8-11	1-1/4	6,600	1	6514-076	38.57
Knot Type – Single Row – Heavy Duty – Stainless Steel							
4	.014	5/8-11	1-1/4	9,000	1	6512-406	63.83
4	.023	5/8-11	1-1/4	9,000	1	6512-416	61.17
4	.014	5/8-11	1-3/8	6,600	1	6512-456	124.03
6	.023	5/8-11	1-3/8	6,600	1	6512-476	107.48

Mighty-Mite Brushes for small Angle Grinders

Knot Type Wire Wheel— Stringer Bead Twist

DIA.	WIRE SIZE	ARBOR HOLE	TRIM LENGTH	FACE WIDTH	MAX SAFE FREE SPEED (RPM)	STD. PKG.	ITEM NO.	PRICE EACH
4	.020	5/8-11	7/8	3/16	20,000	5	6513-131	\$16.45
4	.020	M 10 x 1.25	7/8	3/16	20,000	5	6513-125	16.45
4	Stainless .020	M 10 x 1.25	7/8	3/16	20,000	5	6513-132	27.86
4	Stainless .020	5/8-11	7/8	3/16	20,000	5	6513-138	28.15



Knot Type Wire Wheel Cable Twist



Crimped Wire Cup Brush



DIA.	WIRE SIZE	ARBOR HOLE	TRIM LENGTH	FACE WIDTH	MAX SAFE FREE SPEED (RPM)	STD. PKG.	ITEM NO.	PRICE EACH
4	.020	5/8-11	7/8	1/4	20,000	5	6513-266	\$20.57

DIA.	WIRE SIZE	ARBOR HOLE	TRIM LENGTH	FACE WIDTH	MAX SAFE FREE SPEED (RPM)	STD. PKG.	ITEM NO.	PRICE EACH
3	.014	M10 x 1.25	7/8		14,000	1	6513-240	\$17.24
3	.014	5/8-11	7/8		14,000	1	6513-245	17.24

Knot Type Cup Brush Single Row



DIA.	WIRE SIZE	ARBOR HOLE	TRIM LENGTH	MAX SAFE FREE SPEED (RPM)	STD. PKG.	ITEM NO.	PRICE EACH
2-3/4	.020	M10 x 1.25	7/8	14,000	1	6513-281	\$18.45
2-3/4	.020	1/2-13	7/8	14,000	1	6513-285	18.45
2-3/4	.020	5/8-11	7/8	14,000	1	6513-286	18.45

Crimped Wire Bevel Brush



DIA.	WIRE SIZE	ARBOR HOLE	TRIM LENGTH	FACE WIDTH	MAX SAFE FREE SPEED (RPM)	STD. PKG.	ITEM NO.	PRICE EACH
3-3/8	.0118	M 10 x 1.25	1/2	1/2	12,500	1	6513-091	\$15.81
3-3/8	.0118	M 10 x 1.25	1/2	1/2	12,500	1	6513-095	15.81

Nylox Filament Brushes

Nylox Wheels Crimped Filament



2

DIA.	ARBOR HOLE	FILAMENT DIAM. AND GRIT SIZE	TRIM LENGTH	FACE WIDTH	THICKNESS THROUGH ARBOR	MAX SAFE FREE SPEED (RPM)	STD. PKG.	ITEM NO.	PRICE EACH
6	2	.002/320	1-1/4	1	1-1/16	5,000	2	6583-010	\$58.08
6	2	.035/180	1-1/4	1	1-1/16	5,000	2	6583-030	58.08
6	2	.040/120	1-1/4	1	1-1/16	5,000	2	6583-040	58.08
6	2	.040/80	1-1/4	1	1-1/16	5,000	2	6583-050	58.08
8	2	.002/320	2-1/4	1	3/4	5,000	2	6583-110	80.40
8	2	.035/180	2-1/4	1	3/4	5,000	2	6583-130	80.40
8	2	.040/120	2-1/4	1	3/4	5,000	2	6583-140	80.40
10	2	.040/80	2-1/4	1	3/4	5,000	2	6583-150	80.40
10	2	.002/320	3	1	1-1/16	4,500	2	6583-310	107.51
10	2	.035/180	3	1	1-1/16	4,500	2	6583-330	107.51
10	2	.040/120	3	1	1-1/16	4,500	2	6583-340	107.51
10	2	.040/80	3	1	1-1/16	4,500	2	6583-350	107.51

Other arbor holes available using metal adapter. Please specify.

Nylox Cup Brushes



2

DIA.	ARBOR HOLE	FILAMENT DIAM. AND GRIT SIZE	TRIM LENGTH	THICKNESS THROUGH ARBOR	MAX SAFE FREE SPEED (RPM)	STD. PKG.	ITEM NO.	PRICE EACH
2-3/4	1/4 Stem	.022/320	1-1/4	1-1/16	6,000	1	6514-401	\$32.24
2-3/4	1/4 Stem	.035/180	1-1/4	1-1/16	6,000	1	6514-403	32.06
2-3/4	1/4 Stem	.040/120	1-1/4	1-1/16	6,000	1	6514-404	32.06
3-1/2	5/8-11	.035/180	1-1/2	3/4	12,000	1	6514-413	44.44
3-1/2	5/8-11	.040/120	1-1/2	3/4	8,000	1	6514-414	44.44
5	5/8-11	.040/120	1-1/4	3/4	8,000	1	6514-576	72.51
6	5/8-11	.040/120	1-1/4	1-1/16	6,500	1	6514-516	78.28
6	5/8-11	.040/80	1-1/4	1-1/16	6,000	1	6514-506	78.28

Nylox Tube Brushes



2

DIA.	FILAMENT DIAM. AND GRIT SIZE	BRUSH LENGTH	STEM DIA.	OVERALL LENGTH	STD. PKG.	ITEM NO.	PRICE EACH
1/4	.002/320	1-1/2	1/8	4	10	6521-126	\$8.13
3/8	.035/180	1-1/2	1/8	4	10	6521-128	8.23
1/2	.040/120	2	5/32	5	10	6521-130	7.20
5/8	.002/320	2	7/32	5	10	6521-132	7.57
3/4	.035/180	2-1/2	7/32	5-1/2	10	6521-134	7.67
7/8	.040/120	2-1/2	1/4	5-1/2	10	6521-136	8.16
1	.040/120	2-1/2	1/4	5-1/2	10	6521-138	7.76
1-1/8	.002/320	2-1/2	1/4	5-1/2	10	6521-302	7.60
1-1/4	.035/180	2-1/2	1/4	5-1/2	10	6521-306	8.29
1-1/2	.040/120	2-1/2	1/4	5-1/2	10	6521-309	8.64

Crimped Filament Disc Silicon Carbide - Composite Hub



2

DIAMETER INCHES	FILAMENT DIA./GRIT	ARBOR HOLE	TRIM LENGTH	MAX. RPM	ITEM NO.	PRICE EACH
4"	.022/320	7/8"	1-1/2"	2,500	6585-812	\$ 99.16
4"	.035/180	7/8"	1-1/2"	2,500	6585-814	99.16
4"	.040/120	7/8"	1-1/2"	2,500	6585-816	99.16
4"	.040/80	7/8"	1-1/2"	2,500	6585-818	99.16
6"	.035/180	7/8"	1-1/2"	2,000	6585-850	148.25
6"	.040/120	7/8"	1-1/2"	2,000	6585-852	148.25
6"	.040/80	7/8"	1-1/2"	2,000	6585-854	148.25
8"	.022/320	7/8"	1-1/2"	2,000	6585-906	POA
8"	.035/180	7/8"	1-1/2"	2,000	6585-908	232.31
8"	.040/120	7/8"	1-1/2"	2,000	6585-912	232.31
8"	.040/80	7/8"	1-1/2"	2,000	6585-914	232.31

Rectangular Filament Disc (.045 x .090) Silicon Carbide- Composite Hub

2

DIAMETER INCHES	ARBOR HOLE	GRIT SIZE	TRIM LENGTH	MAX. RPM	ITEM NO.	PRICE EACH
4"	7/8"	180	1-1/2"	2,500	6585-822	\$109.06
4"	7/8"	120	1-1/2"	2,500	6585-824	109.06
4"	7/8"	80	1-1/2"	2,500	6585-826	109.06
6"	7/8"	180	1-1/2"	2,000	6585-858	POA
6"	7/8"	120	1-1/2"	2,000	6585-860	150.09
6"	7/8"	80	1-1/2"	2,000	6585-862	150.09
8"	7/8"	120	1-1/2"	2,000	6585-920	239.02
8"	7/8"	80	1-1/2"	2,000	6585-922	239.02

Nylon Disc Brush Drive Arbors

Mounts Weiler disc brushes to any type of milling machine or CNC machine

4

DESCRIPTION	ITEM NO.	PRICE EACH
For 4" diameter disc brushes with 1-1/4" diameter bolt circle	6507-700	\$183.78
For 6" diameter disc brushes with 3" diameter bolt circle	6507-701	224.64
For 8" diameter disc brushes with 3" diameter bolt circle	6507-702	243.63
Standard 3/4" diameter shaft, 2" long. Standard 7/8" diameter shouldered spindle.		

Power and Hand Tube Brushes



Single Stem, Single Spiral "STS" Type - Eye Handle

DIA.	WIRE SIZE	BRUSH LENGTH	STEM DIAM.	OVERALL LENGTH	STD. PKG.	ITEM NO.	PRICE EACH
Single Stem, Single Spiral "STS" Type – Eye Handle							
3/16	.003	1-1/2	3/32	7	10	6521-090	\$4.57
3/16	.005	1-1/2	3/32	7	10	6521-091	4.57
1/4	.003	1-1/2	3/32	7	10	6521-092	5.13
1/4	.005	1-1/2	3/32	7	10	6521-093	4.43
3/8	.004	2	1/8	8	10	6521-094	4.62
3/8	.006	2	1/8	8	10	6521-095	3.63
1/2	.004	2	1/8	8	10	6521-096	4.62
1/2	.006	2	1/8	8	10	6521-097	3.63
Single Stem, Single Spiral "STS" Type							
1/4	.004	1	1/8	3-1/2	10	6521-081	4.73
3/8	.008	1	1/8	3-1/2	10	6521-240	3.95
1/2	.005	1	3/16	3-1/2	10	6521-083	4.83
5/8	.005	1	3/16	3-1/2	10	6521-084	4.83
3/4	.006	1	7/32	3-1/2	10	6521-085	4.83
7/8	.006	1	7/32	3-1/2	10	6521-086	4.86
1	.008	1	1/4	3-1/2	10	6521-087	5.84

Single Stem, Round "SM" Type Stainless Steel Stem



Single Stem, Round "SM" Type – Stainless Steel Stem							
1/4	.004	1	1/8	3-1/2	10	6521-072	\$4.09
3/8	.004	1	1/8	3-1/2	10	6521-073	4.15
3/8	.008	1	3/16	3-1/2	10	6521-264	3.57
1/2	.005	1	3/16	3-1/2	10	6521-074	3.80
5/8	.005	1	3/16	3-1/2	10	6521-075	3.94
5/8	.008	1	3/16	3-1/2	10	6521-265	4.51
3/4	.006	1	7/32	3-1/2	10	6521-076	4.51
3/4	.008	1	7/32	3-1/2	10	6521-266	4.46
7/8	.006	1	7/32	3-1/2	10	6521-077	4.66
1	.005	1	1/4	3-1/2	10	6521-078	5.13
1-1/8	.008	1	1/4	3-1/2	10	6521-079	5.13
1-1/4	.008	1	1/4	3-1/2	10	6521-080	5.13

Single Stem, Double Spiral "DS" Type



Single Stem, Double Spiral "DS" Type							
1/2	.006	2	5/32	5	10	6521-107	\$9.78
5/8	.008	2	7/32	5	10	6521-109	9.94
3/4	.0104	2-1/2	1/4	5-1/2	10	6521-111	10.11
7/8	.0104	2-1/2	1/4	5-1/2	10	6521-113	10.49
1	.0104	2-1/2	1/4	5-1/2	10	6521-115	10.30
1-1/4	.0104	2-1/2	1/4	5-1/2	10	6521-167	10.76

End Brushes



Solid End



Knot Type



Crimped Wire Cup

DIA.	WIRE SIZE	TRIM LENGTH	MAX SAFE FREE SPEED (RPM)	STD. PKG.	ITEM NO.	PRICE EACH	STAINLESS	
							ITEM NO.	PRICE EACH
Solid End								
1/2	.006	7/8	25,000	10	6510-001	\$7.12	6510-013	\$9.71
1/2	.0104	7/8	25,000	10	6510-002	6.12	6510-014	8.38
1/2	.014	7/8	25,000	10	6510-003	6.12	6510-015	8.28
1/2	.020	7/8	25,000	10	6510-004	5.82	6510-016	8.22
3/4	.006	7/8	22,000	10	6510-005	10.94	6510-017	12.21
3/4	.0104	7/8	22,000	10	6510-006	8.01	6510-018	10.95
3/4	.014	7/8	22,000	10	6510-007	7.84	6510-019	10.95
3/4	.020	7/8	22,000	10	6510-008	7.36	6510-020	10.69
1	.006	7/8	22,000	10	6510-009	14.74	6510-021	18.77
1	.0104	7/8	22,000	10	6510-010	9.43	6510-022	16.11
1	.014	7/8	22,000	10	6510-011	9.43	6510-023	15.75
1	.020	7/8	22,000	10	6510-012	8.90	6510-024	15.42
Knot Type								
3/4	.020	7/8	20,000	10	6510-026	13.83	6510-030	21.38
1-1/8	.014	7/8	20,000	10	6510-027	14.46	6510-031	27.64
1-1/8	.020	7/8	20,000	10	6510-028	14.22	6510-032	24.76
Crimped Wire Cup Brushes								
1-3/4"	.006	3/4"	13,000	10	6514-300	10.72	-	-
1-3/4"	.0118	3/4"	13,000	10	6514-301	9.47	6514-304	19.52
2-3/4"	.0118	7/8"	6,000	1	6514-302	14.50	-	-

Conflex Narrow Face Crimped Wire Wheel



DIA.	WIRE SIZE	TRIM LENGTH	MAX SAFE FREE SPEED (RPM)	STD. PKG.	ITEM NO.	PRICE EACH	STAINLESS	
							ITEM NO.	PRICE EACH
2	.006	1/2	20,000	10	6517-609	\$13.20	-	-
2	.0118	1/2	20,000	10	6517-610	11.80	-	-
2 1/2	.006	3/4	20,000	10	6517-612	15.13	6517-611	\$18.13
2 1/2	.014	3/4	20,000	10	6517-614	10.05	-	-
3	.008	1	20,000	10	6517-615	15.36	-	-
3	.0118	1	20,000	10	6517-616	11.66	-	-
3	.014	1	20,000	10	6517-617	10.89	6517-618	25.12

Maintenance Brushes

Hand Wire Scratch Brushes

4

Curved Handle



FILL MATERIAL	NUMBER OF ROWS	BLOCK SIZE	BRUSH PART	TRIM LENGTH	STD. PKG.	ITEM NO.	PRICE EACH
.012 STEEL	3 x 19	13 x 1/2 x 1	6	1	12	6525-150	\$1.90
.012 SS	3 x 19	13 x 1/2 x 1	6	1	12	6525-154	2.86
.012 STEEL†	3 x 19	14 x 7/8	5-1/2	1-3/16	12	6544-055	3.52
.012 SS	4 x 18	14 x 1-1/8	6	1	12	6525-202	3.86
.012 STEEL†	4 x 19	14 x 1-1/8	6	1-3/16	12	6544-058	4.40

† With Scraper

Block Type



FILL MATERIAL	NUMBER OF ROWS	BLOCK SIZE	TRIM LENGTH	STD. PKG.	ITEM NO.	PRICE EACH
.012 STEEL	6 x 19	7-1/4 x 2-1/4	1-5/8	12	6544-067	\$5.54

Scraper Type



FILL MATERIAL	NUMBER OF ROWS	BLOCK SIZE	BRUSH PART	TRIM LENGTH	STD. PKG.	ITEM NO.	PRICE EACH
.012 STEEL	4 x 11	11 x 1-1/2	5	1-5/8	12	6525-211	\$3.11

Shoe Handle



FILL MATERIAL	NUMBER OF ROWS	BLOCK SIZE	BRUSH PART	TRIM LENGTH	STD. PKG.	ITEM NO.	PRICE EACH
.012 STEEL	4 x 16	10 x 1	5	1	12	6525-100	\$2.06
.012 SS	4 x 16	10 x 1	5	1	12	6525-104	3.44
.012 STEEL†	4 x 16	10 x 1-1/8	5	1-3/16	12	6544-065	3.88

† With Scraper

Small



HANDLE	FILL MATERIAL	NUMBER OF ROWS	BLOCK SIZE	BRUSH PART	TRIM LENGTH	STD. PKG.	ITEM NO.	PRICE EACH
Plastic	.006 SS	3 x 7	7-1/2 x 1/2	1-3/8	1/2	36	6544-075	\$2.66
Wood	.006 SS	3 x 7	7-1/2 x 1/2	1-3/8	1/2	36	6544-167	2.61
Wood	.006 Brass	3 x 7	7-1/2 x 1/2	1-3/8	1/2	36	6544-189	2.66

Chip and Oil Brushes

Natural White Bristle
Wood Handle



WIDTH	THICKNESS	BRISTLE LENGTH	STD. PKG.	ITEM NO.	PRICE EACH
1/2	5/16	1-3/4	36	6540-065	\$0.46
1	5/16	1-3/4	36	6540-066	0.59
1-1/2	5/16	1-3/4	24	6540-067	0.75
2	5/16	1-3/4	24	6540-068	0.97
2-1/2	3/8	1-3/4	12	6540-069	1.56
3	3/8	1-3/4	12	6540-070	1.60
4	5/8	2	12	6540-071	3.59

Counter Dusters



FILL MATERIAL	BRUSH LENGTH	TRIM LENGTH	STD. PKG.	ITEM NO.	PRICE EACH
Black Tampico	8	2-1/2	12	6525-251	\$5.77
Black Synthetic	8	2-1/2	12	6525-252	4.58
Black Horsehair	8	2-1/8	12	6544-003	9.40
Grey Tampico	8	2-1/2	12	6544-004	5.55

Parts Cleaning Brush



FILL MATERIAL	DIA.	BRISTLE LENGTH	STD. PKG.	ITEM NO.	PRICE EACH
Nylon	1	2-1/2	12	6525-221	\$2.50
Tampico	1	2-3/4	12	6525-222	2.61

Tin Handle Acid Brushes

Black Horsehair



WIDTH	TRIM LENGTH	OVERALL LENGTH	STD. PKG.	ITEM NO.	PRICE EACH
3/8	3/4	5-3/4	144	6544-089	\$0.22
1/2	3/4	5-3/4	144	6544-090	0.26

Floor Brushes



DESCRIPTION	TRIM LENGTH	STD. PKG.	ITEM NO.	PRICE EACH
Fine Sweeping				
18 Block Black Tampico	2-7/8	1	6525-231	\$ 10.41
24 Block Black Synthetic	2-7/8	1	6525-232	14.86
Medium Sweeping				
18 Block Synthetic	3	1	6525-234	9.53
24 Block Synthetic	3	1	6525-235	13.29

DESCRIPTION	TRIM LENGTH	STD. PKG.	ITEM NO.	PRICE EACH
Coarse Sweeping				
18 Block Synthetic	3-1/4	1	6525-238	\$ 9.42
24 Block Synthetic	3-1/4	1	6525-239	13.85
Garage Sweeping				
18 Block Palmyra	4	1	6525-241	8.48
24 Block Palmyra	4	1	6525-242	11.88

Handles

Threaded End —
5" Overall Length

Order No. 6544-018

Price Each \$.49

Vitrified Bonded for Rich Stock Removal and Excellent Rigidity for Precision Grinding

WA – White Aluminum Oxide

Friable grain for light grinding of all steels, particularly tool & die steels.

AZ – Premium Blue Aluminum Oxide

Suitable for HSS grinding on materials 55RC and above. Exceptionally cool, fast cutting.

CG – Green Silicon Carbide

General purpose grinding on tungsten carbide and non-ferrous metals.

AS3 – Synthetic Ceramic Blend

Features a blend of synthetic ceramic grain with PA and WA grains for optimum fracturing. Provides a continuous, sharp cutting action.



32A – Premium Aluminum Oxide

Outstanding firm holding wheels with free cutting grain, ideal for medium to heavy stock removal. Excellent versatility and performance on a wide range of materials.



RA – Ruby Aluminum Oxide

For fast stock removal on tool steels below 55RC and for high chromium steels. This grain is harder than the PA and AZ.

6 x 1/2 x 1-1/4 – No Recess

			WHITE ALUMINUM OXIDE (TYPE WA)		PREMIUM BLUE ALUMINUM OXIDE (TYPE AZ)		SILICON CARBIDE (TYPE CG)		SYNTHETIC CERAMIC GRAIN (TYPE AS3)		
GRIT/HARDNESS	MAX RPM	CTN QTY	ORDER NO.	PRICE EACH	ORDER NO.	PRICE EACH	ORDER NO.	PRICE EACH	CTN QTY	ORDER NO.	PRICE EACH
60K	4456	10	-	-	3323-024	\$11.25	-	-	-	-	-

7 x 1/4 x 1-1/4 – No Recess

			WHITE ALUMINUM OXIDE (TYPE WA)		PREMIUM BLUE ALUMINUM OXIDE (TYPE AZ)		SILICON CARBIDE (TYPE CG)		SYNTHETIC CERAMIC GRAIN (TYPE AS3)		
GRIT/HARDNESS	MAX RPM	CTN QTY	ORDER NO.	PRICE EACH	ORDER NO.	PRICE EACH	ORDER NO.	PRICE EACH	CTN QTY	ORDER NO.	PRICE EACH
46I	3760	10	3320-102	\$9.55	3323-102	\$9.65	-	-	-	-	-
60I	3760	10	3320-120	9.55	3323-120	9.65	3275-120	\$10.60	-	-	-
60J	3760	10	3320-122	9.55	3323-122	9.65	-	-	-	-	-
60K	3760	10	3320-124	9.55	3323-124	9.65	-	-	3	3326-124	\$15.50
80I	3760	10	-	-	-	-	3275-130	10.60	-	-	-
80J	3760	10	3320-130	9.55	3323-130	9.65	-	-	-	-	-
80K	3760	10	3320-132	9.55	3323-132	9.65	-	-	3	3326-134	15.50
100I	3760	10	-	-	-	-	3275-140	10.60	-	-	-
100K	3760	10	3320-148	9.55	3323-148	9.65	-	-	-	-	-
120K	3760	10	3320-162	9.55	-	-	-	-	-	-	-
150K	3760	10	3320-186	9.55	3323-186	9.65	-	-	-	-	-

† Limited Quantities

7 x 1/2 x 1-1/4 – No Recess

			WHITE ALUMINUM OXIDE (TYPE WA)		PREMIUM BLUE ALUMINUM OXIDE (TYPE AZ)		GRAY ALUMINUM OXIDE (TYPE 32A)		SILICON CARBIDE (TYPE CG)		SYNTHETIC CERAMIC GRAIN (TYPE AS3)		
GRIT/HARDNESS	MAX RPM	CTN QTY	ORDER NO.	PRICE EACH	ORDER NO.	PRICE EACH	ORDER NO.	PRICE EACH	ORDER NO.	PRICE EACH	CTN QTY	ORDER NO.	PRICE EACH
46G	3760	10	3320-300	\$11.95	-	-	-	-	-	-	-	-	-
46H	3760	10	3320-302	11.95	3323-302	\$12.25	3330-302	\$14.50	-	-	2	3326-202	\$25.35
46I	3760	10	3320-304	11.95	3323-304	12.25	3330-304	14.50	-	-	-	-	-
46J	3760	10	3320-306	11.95	3323-306	12.25	3330-306	14.50	-	-	2	3326-204	25.35
46K	3760	10	3320-308	11.95	3323-308	12.25	3330-308	14.50	-	-	-	-	-
60H	3760	10	3320-320	11.95	3323-320	12.25	-	-	-	-	-	-	-
60I	3760	10	3320-322	11.95	3323-322	12.25	3330-322	14.50	3275-320	\$13.45	-	-	-
60J	3760	10	3320-324	11.95	3323-324	12.25	-	-	-	-	-	-	-
60K	3760	10	3320-326	11.95	3323-326	12.25	-	-	-	-	2	3326-224	25.35
60L	3760	10	-	-	3323-328	12.25	-	-	-	-	-	-	-
80H	3760	10	-	-	3323-342	12.25	-	-	-	-	-	-	-
80I	3760	10	-	-	-	-	-	-	3275-330	13.45	-	-	-
80K	3760	10	3320-346	11.95	3323-346	12.25	-	-	-	-	-	-	-
100I	3760	10	-	-	-	-	-	-	3275-340	13.45	-	-	-
100K	3760	10	3320-360	11.95	3323-360	12.25	-	-	-	-	-	-	-
120K	3760	10	3320-374	11.95	3323-374	12.25	-	-	-	-	-	-	-
150K	3760	10	3320-386	11.95	3323-386	12.25	-	-	-	-	-	-	-

Surface Grinding Wheels



2

**Buy
Ctn Qty
Deduct
10%**

Ruby Red Aluminum Oxide

7 x 1/2 x 1-1/4 - No Recess

TYPE RA				
GRIT/HARDNESS	MAX RPM	CTN QTY	ORDER NO.	PRICE EACH
46H	3600	10	3280-102	\$15.15
46J/K	3600	10	3280-108	15.15
60J/K	3600	10	3280-120	15.15

7 x 1/2 x 1-1/4 - Porous Bond - No Recess

			WHITE ALUMINUM OXIDE (TYPE WA)		PREMIUM BLUE ALUMINUM OXIDE (TYPE AZ)		RUBY ALUMINUM OXIDE (TYPE RA)	
GRIT/HARDNESS	MAX RPM	CTN QTY	ORDER NO.	PRICE EACH	ORDER NO.	PRICE EACH	ORDER NO.	PRICE EACH
46H12	3760	10	3320-402†	\$7.25	3323-402	\$13.10	-	-
46G12	3760	10	-	-	-	-	3277-102	\$16.70
60H12	3760	10	-	-	-	-	3277-108	16.70

† Limited Quantities

7 x 3/4 x 1-1/4 - Recessed One Side 3 x 1/4"

			WHITE ALUMINUM OXIDE (TYPE WA)		PREMIUM BLUE ALUMINUM OXIDE (TYPE AZ)		SILICON CARBIDE (TYPE CG)		SYNTHETIC CERAMIC GRAIN (TYPE AS3)		
GRIT/HARDNESS	MAX RPM	CTN QTY	ORDER NO.	PRICE EACH	ORDER NO.	PRICE EACH	ORDER NO.	PRICE EACH	CTN QTY	ORDER NO.	PRICE EACH
46H	3600	10	3320-500	\$15.15	3323-500	\$15.75	-	-	-	-	-
46I	3600	10	-	-	3323-502	15.75	-	-	-	-	-
46J	3600	10	3320-504	15.15	3323-504	15.75	-	-	-	-	-
46K	3600	10	3320-506†	11.90	3323-506	15.75	-	-	-	-	-
60H	3600	10	3320-518	15.15	3323-518†	9.80	-	-	-	-	-
60I	3600	10	3320-520†	7.65	3323-520†	8.45	3275-520	\$16.60	-	-	-
60J	3600	10	3320-522	15.15	3323-522	15.75	-	-	-	-	-
60K	3600	10	3320-524†	11.95	-	-	-	-	-	-	-
80I	3600	10	-	-	-	-	3275-530	16.60	-	-	-
100I	3600	10	-	-	-	-	3275-540	16.60	-	-	-

† Limited Quantities

7 x 1 x 1-1/4 - Recessed One Side 3 x 1/2"

			WHITE ALUMINUM OXIDE (TYPE WA)		PREMIUM BLUE ALUMINUM OXIDE (TYPE AZ)		SILICON CARBIDE (TYPE CG)		SYNTHETIC CERAMIC GRAIN (TYPE AS3)		
GRIT/HARDNESS	MAX RPM	CTN QTY	ORDER NO.	PRICE EACH	ORDER NO.	PRICE EACH	ORDER NO.	PRICE EACH	CTN QTY	ORDER NO.	PRICE EACH
46H	3600	10	3320-700	\$16.85	3323-700	\$17.55	-	-	-	-	-
46I	3600	10	3320-702	16.85	3323-702	17.55	-	-	-	-	-
46J	3600	10	3320-704	16.85	3323-704	17.55	-	-	-	-	-
46K	3600	10	3320-706	16.85	3323-706	17.55	-	-	-	-	-
60H	3600	10	3320-718†	6.60	-	-	-	-	-	-	-
60I	3600	10	3320-720	16.85	-	-	3275-720	\$19.00	-	-	-
60J	3600	10	3320-722	16.85	3323-722	17.55	-	-	-	-	-
60K	3600	10	-	-	3323-724	17.55	-	-	-	-	-
80I	3600	10	-	-	-	-	3275-730	19.00	-	-	-
100I	3600	10	-	-	-	-	3275-740	19.00	-	-	-

† Limited Quantities

8 x 1/4 x 1-1/4 - No Recess

			WHITE ALUMINUM OXIDE (TYPE WA)		PREMIUM BLUE ALUMINUM OXIDE (TYPE AZ)		SILICON CARBIDE (TYPE CG)		SYNTHETIC CERAMIC GRAIN (TYPE AS3)		
GRIT/HARDNESS	MAX RPM	CTN QTY	ORDER NO.	PRICE EACH	ORDER NO.	PRICE EACH	ORDER NO.	PRICE EACH	CTN QTY	ORDER NO.	PRICE EACH
46H	3600	10	3320-850†	\$7.85	-	-	-	-	-	-	-
46K	3600	10	3320-856†	6.60	-	-	-	-	-	-	-
60I	3600	10	3320-868†	7.85	-	-	-	-	-	-	-
60K	3600	10	3320-874	13.45	-	-	-	-	-	-	-
80I	3600	10	-	-	-	-	3275-830	\$16.30	-	-	-
80J	3600	10	3320-884	13.45	-	-	-	-	-	-	-

† Limited Quantities

Surface Grinding Wheels



2

**Buy
Ctn Qty
Deduct
10%**

8 x 1/2 x 1-1/4 - No Recess

			WHITE ALUMINUM OXIDE (TYPE WA)		PREMIUM BLUE ALUMINUM OXIDE (TYPE AZ)		SILICON CARBIDE (TYPE CG)		GREY ALUMINUM OXIDE (TYPE 32A)		SYNTHETIC CERAMIC GRAIN (TYPE AS3)		
GRIT/HARDNESS	MAX RPM	CTN QTY	ORDER NO.	PRICE EACH	ORDER NO.	PRICE EACH	ORDER NO.	PRICE EACH	ORDER NO.	PRICE EACH	CTN QTY	ORDER NO.	PRICE EACH
46H	3600	10	3320-900	\$16.00	3323-900	\$16.35	-	-	-	-	-	-	-
46I	3600	10	3320-902	16.00	3323-902	16.35	-	-	3330-902	\$17.10	-	-	-
46J	3600	10	3320-904	16.00	3323-904	16.35	-	-	3330-904	17.10	-	-	-
46K	3600	10	3320-906	16.00	3323-906	16.35	-	-	-	-	2	3326-406	\$30.95
60H	3600	10	-	-	3323-918	16.35	-	-	-	-	-	-	-
60I	3600	10	3320-920	16.00	3323-920	16.35	3275-920	\$17.90	-	-	-	-	-
60J	3600	10	3320-922	16.00	3323-922	16.35	-	-	-	-	2	3326-424	30.95
60K	3600	10	3320-924	16.00	3323-924	16.35	-	-	-	-	-	-	-
80I	3600	10	-	-	-	-	3275-930	17.90	-	-	-	-	-
80K	3600	10	3320-936	16.00	3323-936	16.35	-	-	-	-	-	-	-
100I	3600	10	-	-	-	-	3275-940	17.90	-	-	-	-	-

8 x 1/2 x 1-1/4 - Porous Bond - No Recess

RUBY ALUMINUM OXIDE (TYPE RA)				
GRIT/HARDNESS	MAX RPM	CTN QTY	ORDER NO.	PRICE EACH
46H12	3600	10	3277-133	\$23.00
60H12	3600	10	3277-138	23.00

8 x 3/4 x 1-1/4 - Recessed One Side 3 x 1/4"

			WHITE ALUMINUM OXIDE (TYPE WA)		PREMIUM BLUE ALUMINUM OXIDE (TYPE AZ)		SILICON CARBIDE (TYPE CG)		SYNTHETIC CERAMIC GRAIN (TYPE AS3)		
GRIT/HARDNESS	MAX RPM	CTN QTY	ORDER NO.	PRICE EACH	ORDER NO.	PRICE EACH	ORDER NO.	PRICE EACH	CTN QTY	ORDER NO.	PRICE EACH
46H	3600	10	3321-000	\$18.95	3324-000	\$19.75	-	-	-	-	-
46J	3600	10	3321-004	18.95	3324-004	19.75	-	-	-	-	-
46K	3600	10	3321-006†	9.60	-	-	-	-	-	-	-
60I	3600	10	3321-020	18.95	-	-	3276-020	\$20.80	-	-	-
60J	3600	10	3321-022	18.95	3324-022	19.75	-	-	-	-	-
60K	3600	10	3321-024	18.95	-	-	-	-	-	-	-
80I	3600	10	-	-	-	-	3276-030†	12.50	-	-	-

† Limited Quantities

8 x 1 x 1-1/4 - Recessed One Side 3 x 1/2"

			WHITE ALUMINUM OXIDE (TYPE WA)		PREMIUM BLUE ALUMINUM OXIDE (TYPE AZ)		SILICON CARBIDE (TYPE CG)		SYNTHETIC CERAMIC GRAIN (TYPE AS3)		
GRIT/HARDNESS	MAX RPM	CTN QTY	ORDER NO.	PRICE EACH	ORDER NO.	PRICE EACH	ORDER NO.	PRICE EACH	CTN QTY	ORDER NO.	PRICE EACH
46H	3600	10	3321-100	\$21.80	3324-100	\$22.95	-	-	-	-	-
46I	3600	10	3321-102	22.05	-	-	-	-	-	-	-
46J	3600	10	3321-104	22.05	3324-104	22.95	-	-	-	-	-
46K	3600	10	3321-106	22.05	-	-	-	-	-	-	-
60I	3600	10	3321-120	22.05	-	-	3276-120	\$24.20	-	-	-
60J	3600	10	3321-122	22.05	3324-122	22.95	-	-	-	-	-
60K	3600	10	3321-124	22.05	-	-	-	-	-	-	-
80I	3600	10	-	-	-	-	3276-130†	14.55	-	-	-
100I	3600	10	-	-	-	-	3276-140	24.20	-	-	-

† Limited Quantities

10 x 1/2 x 3 - No Recess

			WHITE ALUMINUM OXIDE (TYPE WA)		PREMIUM BLUE ALUMINUM OXIDE (TYPE AZ)		SILICON CARBIDE (TYPE CG)		SYNTHETIC CERAMIC GRAIN (TYPE AS3)		
GRIT/HARDNESS	MAX RPM	CTN QTY	ORDER NO.	PRICE EACH	ORDER NO.	PRICE EACH	ORDER NO.	PRICE EACH	CTN QTY	ORDER NO.	PRICE EACH
46J	2630	5	-	-	3324-204†	\$17.00	-	-	-	-	-
60H	2630	5	-	-	3324-218†	17.00	-	-	-	-	-
60J	2630	5	3321-222	\$24.50	-	-	-	-	-	-	-
60K	2630	5	3321-224†	15.45	-	-	-	-	-	-	-

† Limited Quantities



Buy
Ctn Qty
Deduct
10%

10 x 3/4 x 3 – No Recess

			WHITE ALUMINUM OXIDE (TYPE WA)		PREMIUM BLUE ALUMINUM OXIDE (TYPE AZ)		SILICON CARBIDE (TYPE CG)		SYNTHETIC CERAMIC GRAIN (TYPE AS3)		
GRIT/HARDNESS	MAX RPM	CTN QTY	ORDER NO.	PRICE EACH	ORDER NO.	PRICE EACH	ORDER NO.	PRICE EACH	CTN QTY	ORDER NO.	PRICE EACH
46I	2630	5	–	–	3324-302	\$32.30	–	–	–	–	–
60H	2630	5	–	–	3324-318	32.30	–	–	–	–	–
60I	2630	5	3321-320	\$31.35	–	–	–	–	–	–	–
60K	2630	5	3321-324†	13.45	–	–	–	–	–	–	–

† Limited Quantities

10 x 1 x 3 – No Recess

			WHITE ALUMINUM OXIDE (TYPE WA)		PREMIUM BLUE ALUMINUM OXIDE (TYPE AZ)		SILICON CARBIDE (TYPE CG)		SYNTHETIC CERAMIC GRAIN (TYPE AS3)		
GRIT/HARDNESS	MAX RPM	CTN QTY	ORDER NO.	PRICE EACH	ORDER NO.	PRICE EACH	ORDER NO.	PRICE EACH	CTN QTY	ORDER NO.	PRICE EACH
46H	2630	5	3321-500	\$37.30	3324-500	\$38.05	–	–	–	–	–
46I	2630	5	3321-502	37.30	3324-502	38.05	–	–	–	–	–
46J	2630	5	3321-504	37.30	3324-504	38.05	–	–	–	–	–
46K	2630	5	3321-506†	22.45	3324-506	38.05	–	–	3	3326-706	\$92.05
60H	2630	5	–	–	3324-518†	25.40	–	–	–	–	–
60I	2630	5	3321-520†	22.45	3324-520	38.05	–	–	–	–	–
60J	2630	5	3321-522	37.30	3324-522	38.05	–	–	–	–	–
60K	2630	5	3321-524†	22.45	3324-524	38.05	–	–	–	–	–

† Limited Quantities

12x3/4x3 – No Recess

			WHITE ALUMINUM OXIDE (TYPE WA)		PREMIUM BLUE ALUMINUM OXIDE (TYPE AZ)		SILICON CARBIDE (TYPE CG)		SYNTHETIC CERAMIC GRAIN (TYPE AS3)		
GRIT/HARDNESS	MAX RPM	CTN QTY	ORDER NO.	PRICE EACH	ORDER NO.	PRICE EACH	ORDER NO.	PRICE EACH	CTN QTY	ORDER NO.	PRICE EACH
46H	2228	4	–	–	3324-600	\$40.75	–	–	–	–	–
46I	2228	4	3321-602	\$41.50	–	–	–	–	–	–	–
46K	2228	4	3321-606†	24.20	–	–	–	–	–	–	–

† Limited Quantities

12 x 1 x 3 – No Recess

			WHITE ALUMINUM OXIDE (TYPE WA)		PREMIUM BLUE ALUMINUM OXIDE (TYPE AZ)		SILICON CARBIDE (TYPE CG)		SYNTHETIC CERAMIC GRAIN (TYPE AS3)		
GRIT/HARDNESS	MAX RPM	CTN QTY	ORDER NO.	PRICE EACH	ORDER NO.	PRICE EACH	ORDER NO.	PRICE EACH	CTN QTY	ORDER NO.	PRICE EACH
46H	2228	2	3321-700	\$52.50	3324-700	\$52.05	–	–	2	3326-902	\$122.60
46I	2228	2	3321-702	52.50	3324-702	52.05	–	–	–	–	–
46J	2228	2	3321-704	52.50	3324-704	52.05	–	–	2	3326-904	122.60
46K	2228	2	3321-706†	34.60	3324-706	52.05	–	–	–	–	–
60I	2228	2	–	–	3324-720	52.05	–	–	2	3326-922	122.60
60K	2228	2	–	–	3324-724	52.05	–	–	–	–	–

† Limited Quantities



12 x 1 x 5 – No Recess

			WHITE ALUMINUM OXIDE (TYPE WA)		PREMIUM BLUE ALUMINUM OXIDE (TYPE AZ)		SILICON CARBIDE (TYPE CG)		SYNTHETIC CERAMIC GRAIN (TYPE AS3)		
GRIT/HARDNESS	MAX RPM	CTN QTY	ORDER NO.	PRICE EACH	ORDER NO.	PRICE EACH	ORDER NO.	PRICE EACH	CTN QTY	ORDER NO.	PRICE EACH
46H	2228	2	3321-800	\$52.50	3324-800	\$52.05	-	-	2	3326-932	\$122.60
46I	2228	2	3321-802†	29.20	-	-	-	-	-	-	-
46J	2228	2	3321-804	52.50	3324-804	52.05	-	-	-	-	-
46K	2228	2	3321-806†	28.25	3324-806	52.05	-	-	-	-	-
60J	2228	2	3321-822	52.50	3324-822	52.05	-	-	-	-	-
60K	2228	2	3321-824	52.50	3324-824	52.05	-	-	-	-	-

† Limited Quantities

12 x 1-1/2 x 3 – Recessed One Side 7-1/2 x 1/2"

			WHITE ALUMINUM OXIDE (TYPE WA)		PREMIUM BLUE ALUMINUM OXIDE (TYPE AZ)		SILICON CARBIDE (TYPE CG)		SYNTHETIC CERAMIC GRAIN (TYPE AS3)		
GRIT/HARDNESS	MAX RPM	CTN QTY	ORDER NO.	PRICE EACH	ORDER NO.	PRICE EACH	ORDER NO.	PRICE EACH	CTN QTY	ORDER NO.	PRICE EACH
46H	2228	2	3321-900	\$74.50	-	-	-	-	-	-	-
46I	2228	2	3321-902	74.50	-	-	-	-	-	-	-
46J	2228	2	3321-904	74.50	-	-	-	-	-	-	-
60I	2228	2	3321-920	74.50	-	-	-	-	-	-	-

12 x 1-1/2 x 5 – Recessed One Side 7-1/2 x 1/2"

			WHITE ALUMINUM OXIDE (TYPE WA)		PREMIUM BLUE ALUMINUM OXIDE (TYPE AZ)		SILICON CARBIDE (TYPE CG)		SYNTHETIC CERAMIC GRAIN (TYPE AS3)		
GRIT/HARDNESS	MAX RPM	CTN QTY	ORDER NO.	PRICE EACH	ORDER NO.	PRICE EACH	ORDER NO.	PRICE EACH	CTN QTY	ORDER NO.	PRICE EACH
46H	2228	2	3322-000	\$74.50	3325-000	\$73.85	-	-	-	-	-
46I	2228	2	3322-002	74.50	3325-002	73.85	-	-	-	-	-
46J	2228	2	3322-004	74.50	3325-004	73.85	-	-	-	-	-
46K	2228	2	3322-006	74.50	3325-006	73.85	-	-	-	-	-
60I	2228	2	3322-020	74.50	3325-020	73.85	-	-	-	-	-
60J	2228	2	3322-022	74.50	3325-022	73.85	-	-	-	-	-
60K	2228	2	3322-024	74.50	-	-	-	-	-	-	-

12 x 1-1/2 x 5 – Porous Bond – Recessed One Side 7-1/2 x 1/2"

			RUBY ALUMINUM OXIDE (TYPE RA)	
GRIT/HARDNESS	MAX RPM	CTN QTY	ORDER NO.	PRICE EACH
46H12	2190	2	3277-183	\$113.90

12 x 2 x 5 – Recessed Two Sides 7-1/2 x 1/2"

			WHITE ALUMINUM OXIDE (TYPE WA)		PREMIUM BLUE ALUMINUM OXIDE (TYPE AZ)		SILICON CARBIDE (TYPE CG)		SYNTHETIC CERAMIC GRAIN (TYPE AS3)		
GRIT/HARDNESS	MAX RPM	CTN QTY	ORDER NO.	PRICE EACH	ORDER NO.	PRICE EACH	ORDER NO.	PRICE EACH	CTN QTY	ORDER NO.	PRICE EACH
46H	2228	3	3322-100	\$80.90	3325-100	\$80.95	-	-	-	-	-
46I	2228	3	3322-102	80.90	3325-102	80.95	-	-	-	-	-
46J	2228	3	3322-104	80.90	3325-104	80.95	-	-	-	-	-
60H	2228	3	3322-118	80.90	3325-118	80.95	-	-	-	-	-



14 x 1 x 5 – No Recess

GRIT/ HARDNESS	MAX RPM	CTN QTY	WHITE ALUMINUM OXIDE (TYPE WA)		PREMIUM BLUE ALUMINUM OXIDE (TYPE AZ)		GREY ALUMINUM OXIDE (TYPE 32A)		SYNTHETIC CERAMIC GRAIN (TYPE AS3)		
			ORDER NO.	PRICE EACH	ORDER NO.	PRICE EACH	ORDER NO.	PRICE EACH	CTN QTY	ORDER NO.	PRICE EACH
46H	1910	2	-	-	3325-200	\$87.45	3332-200	\$84.15	-	-	-
46I	1910	2	3322-202	\$72.95	3325-202	87.45	3332-202	84.15	-	-	-
46J	1910	2	-	-	3325-204	87.45	-	-	2	3326-954	\$150.60
46K	1910	2	-	-	3325-206	87.45	-	-	-	-	-
60I	1910	2	3322-220	72.95	3325-220	87.45	-	-	-	-	-
60J	1910	2	-	-	3325-222	87.45	-	-	-	-	-
60K	1880	2	3322-224	72.95	3325-224	87.45	-	-	-	-	-

14 x 1-1/2 x 5 – No Recess

GRIT/ HARDNESS	MAX RPM	CTN QTY	WHITE ALUMINUM OXIDE (TYPE WA)		PREMIUM BLUE ALUMINUM OXIDE (TYPE AZ)		GRAY ALUMINUM OXIDE (TYPE 32A)	
			ORDER NO.	PRICE EACH	ORDER NO.	PRICE EACH	ORDER NO.	PRICE EACH
46H	1910	2	3322-250	\$97.85	3325-250	\$117.35	3332-250	\$117.75
46I	1910	2	3322-252	97.85	3325-252	117.35	3332-254	117.75
46J	1910	2	3322-254	97.85	3325-254	117.35	-	-
46K	1910	2	-	-	3325-256	117.35	-	-
60H	1910	2	-	-	3325-268	117.35	-	-
60J	1910	2	-	-	3325-272	117.35	-	-

14 x 1-1/2 x 5 Porous Bond – No Recess

RUBY ALUMINUM OXIDE (TYPE RA)				
GRIT/ HARDNESS	MAX RPM	CTN QTY	ORDER NO.	PRICE EACH
46H12	1910	2	3277-243	\$141.30

14 x 1-1/2 x 5 – Recessed One Side 8 x 1/2"

GRIT/ HARDNESS	MAX RPM	CTN QTY	WHITE ALUMINUM OXIDE (TYPE WA)		PREMIUM BLUE ALUMINUM OXIDE (TYPE AZ)		SYNTHETIC CERAMIC GRAIN (TYPE AS3)	
			ORDER NO.	PRICE EACH	ORDER NO.	PRICE EACH	ORDER NO.	PRICE EACH
46H	1910	2	3322-300	\$97.85	3325-300	\$117.35	-	-
46I	1910	2	3322-302	97.85	3325-302	117.35	-	-
46J	1910	2	3322-304	97.85	3325-304	117.35	-	-
60H	1910	2	3322-318	97.85	-	-	-	-
60I	1910	2	3322-320	97.85	3325-320	117.35	3326-966	\$231.45
60J	1910	2	-	-	3325-322	117.35	-	-
60K	1910	2	-	-	3325-324	117.35	-	-

14 x 1-1/2 x 5 - Porous Bond Recessed One Side 8 x 1/2"

RUBY ALUMINUM OXIDE (TYPE RA)				
GRIT/ HARDNESS	MAX RPM	CTN QTY	ORDER NO.	PRICE EACH
46H12	1910	2	3277-253	\$147.40

14 x 2 x 5 – Recessed One Side 8 x 1"

GRIT/ HARDNESS	MAX RPM	CTN QTY	WHITE ALUMINUM OXIDE (TYPE WA)		PREMIUM BLUE ALUMINUM OXIDE (TYPE AZ)		SILICON CARBIDE (TYPE CG)		SYNTHETIC CERAMIC GRAIN (TYPE AS3)		
			ORDER NO.	PRICE EACH	ORDER NO.	PRICE EACH	ORDER NO.	PRICE EACH	CTN QTY	ORDER NO.	PRICE EACH
46H	1910	1	3322-400	\$111.75	3325-400	\$134.10	-	-	-	-	-
46I	1910	1	3322-402	111.75	3325-402	134.10	-	-	-	-	-
46J	1910	1	3322-404	111.75	3325-404	134.10	-	-	-	-	-
46K	1910	1	3322-406	111.75	3325-406	134.10	-	-	-	-	-
60I	1910	1	3322-420	111.75	-	-	-	-	-	-	-
60J	1910	1	3322-422	111.75	3325-422	134.10	-	-	-	-	-
60K	1910	1	-	-	3325-424	134.10	-	-	-	-	-

*Carton Qty. deduction not applicable

14 x 2 x 5 - Porous Bond – Recessed One Side 8 x 1"

RUBY ALUMINUM OXIDE (TYPE RA)				
GRIT/ HARDNESS	MAX RPM	CTN QTY	ORDER NO.	PRICE EACH
46H12	1880	1	3277-273	\$158.80

*Carton Qty. deduction not applicable

Vitrified Bonded Assortment of the Standard Shapes Most Commonly Used in Tool and Cutter Applications.

WA – White Aluminum Oxide

Friable grain for light grinding of all steels, particularly tool & die steels.

CG – Green Silicon Carbide

Used for non-ferrous metals such as cemented carbides.

AS3 – Synthetic Ceramic Blend

Features a blend of synthetic ceramic grain with PA and WA grains for optimum fracturing. Provides a continuous, sharp cutting action.



4/3 x 1-1/2 x 1-1/4 – Flaring Cup Wheel

			WHITE ALUMINUM OXIDE (TYPE WA)		SILICON CARBIDE (TYPE CG)		SYNTHETIC CERAMIC GRAIN (TYPE AS3)		
GRIT/HARDNESS	MAX RPM	CTN QTY	ORDER NO.	PRICE EACH	ORDER NO.	PRICE EACH	CTN QTY	ORDER NO.	PRICE EACH
46I	6685	10	3102-732†	\$6.55	–	–	3	3103-820	\$28.65
46J	6685	10	3102-733	13.75	–	–	–	–	–
46K	6685	10	3102-734	13.75	–	–	–	–	–
60H	6685	10	3102-741†	9.25	–	–	–	–	–
60I	6685	10	3102-742	13.75	3103-020†	\$7.35	–	–	–
60J	6685	10	3102-743	13.75	–	–	–	–	–
60K	6685	10	3102-744	13.75	–	–	3	3103-830	28.65
80K	6685	10	3102-750	13.75	–	–	–	–	–

† Limited Quantities



5/3-3/4 x 1-3/4 x 1-1/4 – Flaring Cup Wheel

			WHITE ALUMINUM OXIDE (TYPE WA)		SILICON CARBIDE (TYPE CG)		SYNTHETIC CERAMIC GRAIN (TYPE AS3)		
GRIT/HARDNESS	MAX RPM	CTN QTY	ORDER NO.	PRICE EACH	ORDER NO.	PRICE EACH	CTN QTY	ORDER NO.	PRICE EACH
46H	5348	10	3102-802	\$20.65	–	–	–	–	–
46I	5348	10	3102-805	20.65	–	–	3	3103-880	\$38.80
46J	5348	10	3102-803	20.65	–	–	–	–	–
46K	5348	10	3102-804	20.65	–	–	–	–	–
60H	5348	10	3102-816†	POA	–	–	–	–	–
60I	5348	10	3102-815	20.65	3103-120	\$25.15	–	–	–
60J	5348	10	3102-813	20.65	–	–	3	3103-890	38.80
60K	5348	10	3102-814	20.65	–	–	–	–	–
80K	5348	10	3102-820	20.65	–	–	–	–	–



5 x 1-1/2 x 1-1/4 – Straight Cup Wheel

			WHITE ALUMINUM OXIDE (TYPE WA)		SILICON CARBIDE (TYPE CG)		SYNTHETIC CERAMIC GRAIN (TYPE AS3)		
GRIT/HARDNESS	MAX RPM	CTN QTY	ORDER NO.	PRICE EACH	ORDER NO.	PRICE EACH	CTN QTY	ORDER NO.	PRICE EACH
46J	5348	10	3102-853	\$18.90	–	–	–	–	–
46K	5348	10	3102-854	18.90	–	–	–	–	–
60I	5348	10	–	–	3103-220†	\$10.55	–	–	–
60J	5348	10	3102-863	18.90	–	–	–	–	–
60K	5348	10	3102-864	18.90	–	–	–	–	–
80K	5348	10	3102-870	18.90	–	–	–	–	–

† Limited Quantities



Vitrified Bonded Assortment of the Standard Shapes Most Commonly Used in Tool and Cutter Applications.

WA – White Aluminum Oxide

Friable grain for light grinding of all steels, particularly tool & die steels.

CG – Green Silicon Carbide

Used for non-ferrous metals such as cemented carbides.

AS3 – Synthetic Ceramic Blend

Features a blend of synthetic ceramic grain with PA and WA grains for optimum fracturing. Provides a continuous, sharp cutting action.



6 x 1/2 x 1-1/4 – Dish Wheel

GRIT/ HARDNESS	MAX RPM	CTN QTY	WHITE ALUMINUM OXIDE (TYPE WA)		SILICON CARBIDE (TYPE CG)		SYNTHETIC CERAMIC GRAIN (TYPE AS3)		
			ORDER NO.	PRICE EACH	ORDER NO.	PRICE EACH	CTN QTY	ORDER NO.	PRICE EACH
46K	4456	10	3102-914	\$13.25	-	-	-	-	-
60J	4456	10	3102-923	13.25	-	-	-	-	-
60K	4456	10	3102-924	13.25	-	-	-	-	-
80K	4456	10	3102-930†	8.65	-	-	-	-	-

† Limited Quantities



6 x 1 x 4 – Plate Mounted Wheels

GRIT/ HARDNESS	MAX RPM	CTN QTY	WHITE ALUMINUM OXIDE (TYPE WA)		SILICON CARBIDE (TYPE CG)		SYNTHETIC CERAMIC GRAIN (TYPE AS3)		
			ORDER NO.	PRICE EACH	ORDER NO.	PRICE EACH	CTN QTY	ORDER NO.	PRICE EACH
46K	3450	10	3103-960	\$29.95	-	-	-	-	-
60I	3450	10	-	-	3103-920	\$33.75	-	-	-
80I	3450	10	-	-	3103-930	33.75	-	-	-
100I	3450	10	-	-	3103-940	33.75	-	-	-
120I	3450	10	-	-	3103-950	33.75	-	-	-



Vitrified Bond Silicon Carbide Dressing Sticks

For cleaning, dressing and reshaping vitrified bond grinding wheels.

SIZE	GRADE	ORDER NO.	PRICE EACH
6 x 1 x 1	24S	3132-998	\$3.70
8 x 1 x 1	24S	3132-999	4.50



Bench and Pedestal Wheels



2

Vitrified Bonded Straight Wheels
Used for Off-hand Tool Sharpening
and General Purpose Bench Grinding
Applications.

Buy
Ctn Qty
Deduct
10%



A – Dark Aluminum Oxide

The most common of all grains. This grain is used for heavy duty general purpose work.

CG – Green Silicon Carbide

Used for non-ferrous metals such as cemented carbides.

6 x 1/2 x H (Telescopic Bushing 3/4, 5/8, 1/2")

			DARK ALUMINUM OXIDE (TYPE A)		SILICON CARBIDE (TYPE CG)	
GRIT/HARDNESS	MAX RPM	CTN QTY	ORDER NO.	PRICE EACH	ORDER NO.	PRICE EACH
24Q	4138	10	3102-001	\$11.90	–	–
360	4138	10	3102-002†	4.15	–	–
46M	4138	10	3102-003	11.90	–	–
60I	4138	10	–	–	3102-402	\$10.90
60M	4138	10	3102-004	11.90	–	–
80I	4138	10	–	–	3102-404	10.90
80M	4138	10	3102-005	11.90	–	–
100I	4138	10	–	–	3102-406	10.90

† Limited Quantities

6 x 3/4 x H (Telescopic Bushing 3/4, 5/8, 1/2")

			DARK ALUMINUM OXIDE (TYPE A)		SILICON CARBIDE (TYPE CG)	
GRIT/HARDNESS	MAX RPM	CTN QTY	ORDER NO.	PRICE EACH	ORDER NO.	PRICE EACH
24Q	4138	10	3102-021	\$10.70	–	–
360	4138	10	3102-022	10.70	–	–
46M	4138	10	3102-023	10.70	–	–
60I	4138	10	–	–	3102-422	\$12.05
60M	4138	10	3102-024	10.70	–	–
80I	4138	10	–	–	3102-424	12.05
80M	4138	10	3102-025	10.70	–	–
100I	4138	10	–	–	3102-426	12.05

6 x 1 x H (Telescopic Bushing 3/4, 5/8, 1/2")

			DARK ALUMINUM OXIDE (TYPE A)		SILICON CARBIDE (TYPE CG)	
GRIT/HARDNESS	MAX RPM	CTN QTY	ORDER NO.	PRICE EACH	ORDER NO.	PRICE EACH
24Q	4138	10	3102-041	\$12.25	–	–
360	4138	10	3102-042	12.25	–	–
46M	4138	10	3102-043	12.25	–	–
60I	4138	10	–	–	3102-442	\$13.75
60M	4138	10	3102-044	12.25	–	–
80I	4138	10	–	–	3102-444	13.75
80M	4138	10	3102-045	12.25	–	–
100I	4138	10	–	–	3102-446	13.75

7 x 3/4 x H (Telescopic Bushing 3/4, 5/8, 1/2")

			DARK ALUMINUM OXIDE (TYPE A)		SILICON CARBIDE (TYPE CG)	
GRIT/HARDNESS	MAX RPM	CTN QTY	ORDER NO.	PRICE EACH	ORDER NO.	PRICE EACH
24Q	3600	10	3102-061†	\$6.90	–	–
360	3600	10	3102-062†	6.30	–	–
60I	3600	10	–	–	3102-462	\$14.50
60M	3600	10	3102-064	15.35	–	–
80I	3600	10	–	–	3102-464	14.50
80M	3600	10	3102-065†	POA	–	–
100I	3600	10	–	–	3102-466	14.50

† Limited Quantities

7 x 1 x H (Telescopic Bushing 3/4, 5/8, 1/2")

			DARK ALUMINUM OXIDE (TYPE A)		SILICON CARBIDE (TYPE CG)	
GRIT/HARDNESS	MAX RPM	CTN QTY	ORDER NO.	PRICE EACH	ORDER NO.	PRICE EACH
24Q	3600	10	3102-081	\$14.20	–	–
360	3600	10	3102-082	14.20	–	–
46M	3600	10	3102-083	14.20	–	–
60I	3600	10	–	–	3102-482	\$16.05
60M	3600	10	3102-084	14.20	–	–
80I	3600	10	–	–	3102-484	16.05
80M	3600	10	3102-085	14.20	–	–
100I	3600	10	–	–	3102-486	16.05

8 x 1 x H (Telescopic Bushing 3/4, 5/8, 1/2")

			DARK ALUMINUM OXIDE (TYPE A)		SILICON CARBIDE (TYPE CG)	
GRIT/HARDNESS	MAX RPM	CTN QTY	ORDER NO.	PRICE EACH	ORDER NO.	PRICE EACH
24Q	3600	10	3102-105	\$18.35	–	–
360	3600	10	3102-106	18.35	–	–
46M	3600	10	3102-107	18.35	–	–
60I	3600	10	–	–	3102-522	\$20.70
60M	3600	10	3102-108	18.35	–	–
80I	3600	10	–	–	3102-524	20.70
80M	3600	10	3102-109	18.35	–	–
100I	3600	10	–	–	3102-526	20.70

10 x 1 x 1-1/4" 14

			DARK ALUMINUM OXIDE (TYPE A)		SILICON CARBIDE (TYPE CG)	
GRIT/HARDNESS	MAX RPM	CTN QTY	ORDER NO.	PRICE EACH	ORDER NO.	PRICE EACH
24Q	2483	5	3102-141	\$36.50	–	–
360	2483	5	3102-142	36.50	–	–
46M	2483	5	3102-143	36.50	–	–
60I	2483	5	–	–	3102-542	\$40.65
60M	2483	5	3102-144	36.50	–	–
80I	2483	5	–	–	3102-544	40.65
80M	2483	5	3102-145	36.50	–	–
100I	2483	5	–	–	3102-546	40.65

10 x 1-1/2 x 1-1/4" 13

			DARK ALUMINUM OXIDE (TYPE A)		SILICON CARBIDE (TYPE CG)	
GRIT/HARDNESS	MAX RPM	CTN QTY	ORDER NO.	PRICE EACH	ORDER NO.	PRICE EACH
24Q	2483	4	3102-161	\$46.10	–	–
360	2483	4	3102-162	46.10	–	–
46M	2483	4	3102-163	46.10	–	–
60I	2483	4	–	–	3102-562	\$48.55
60M	2483	4	3102-164	46.10	–	–
80I	2483	4	–	–	3102-564	48.55
80M	2483	4	3102-165	46.10	–	–
100I	2483	4	–	–	3102-566	48.55

Bench and Pedestal Wheels

2



Vitrified Bonded Straight Wheels Used for Off-hand Tool Sharpening and General Purpose Bench Grinding Applications



Buy Ctn Qty Deduct 10% except 16" and 18" Diameters

12 x 1 x 1-1/4"

			DARK ALUMINUM OXIDE (TYPE WA)		SILICON CARBIDE (TYPE CG)	
GRIT/HARDNESS	MAX RPM	CTN QTY	ORDER NO.	PRICE EACH	ORDER NO.	PRICE EACH
24Q	2069	2	3102-181	\$56.60	-	-
36O	2069	2	3102-182†	29.50	-	-
46M	2069	2	3102-183	56.60	-	-
60I	2069	2	-	-	3102-582	\$61.95
60M	2069	2	3102-184	56.60	-	-
80I	2069	2	-	-	3102-584†	POA

† Limited Quantities

12 x 1-1/2 x 1-1/4"

			DARK ALUMINUM OXIDE (TYPE WA)		SILICON CARBIDE (TYPE CG)	
GRIT/HARDNESS	MAX RPM	CTN QTY	ORDER NO.	PRICE EACH	ORDER NO.	PRICE EACH
24Q	2069	2	3102-205	\$70.45	-	-
36O	2069	2	3102-206	70.45	-	-
46M	2069	2	3102-207	70.45	-	-
60I	2069	2	-	-	3102-602	\$82.75
60M	2069	2	3102-208	70.45	-	-
80I	2069	2	-	-	3102-604	82.75

12 x 2 x 1-1/2"

			DARK ALUMINUM OXIDE (TYPE WA)		SILICON CARBIDE (TYPE CG)	
GRIT/HARDNESS	MAX RPM	CTN QTY	ORDER NO.	PRICE EACH	ORDER NO.	PRICE EACH
24Q	2069	3	3102-221	\$71.60	-	-
36O	2069	3	3102-222	71.60	-	-
46M	2069	3	3102-223	71.60	-	-
60I	2069	3	-	-	3102-622	\$84.70
60M	2069	3	3102-224	71.60	-	-
80I	2069	3	-	-	3102-624	84.70
80M	2069	3	3102-225	71.60	-	-
100I	2069	3	-	-	3102-626	84.70

14 x 2 x 1-1/4" To 1-1/2"

			DARK ALUMINUM OXIDE (TYPE WA)		SILICON CARBIDE (TYPE CG)	
GRIT/HARDNESS	MAX RPM	CTN QTY	ORDER NO.	PRICE EACH	ORDER NO.	PRICE EACH
24Q	2069	3	3102-271	\$110.55	-	-
36O	2069	3	3102-272	110.55	-	-
46M	2069	3	3102-273	110.55	-	-
60I	2069	3	-	-	3102-642	\$135.45
60M	2069	3	3102-274	110.55	-	-
80I	2069	3	-	-	3102-644	135.45
80M	2069	3	3102-275	110.55	-	-

16 x 2 x 1-1/2"

			DARK ALUMINUM OXIDE (TYPE WA)		SILICON CARBIDE (TYPE CG)	
GRIT/HARDNESS	MAX RPM	CTN QTY	ORDER NO.	PRICE EACH	ORDER NO.	PRICE EACH
24Q	1550	1	3102-301	\$165.75	-	-
36O	1550	1	3102-302	165.75	-	-

Carton quantity discount does not apply

18 x 3 x 1-1/2"

			DARK ALUMINUM OXIDE (TYPE WA)		SILICON CARBIDE (TYPE CG)	
GRIT/HARDNESS	MAX RPM	CTN QTY	ORDER NO.	PRICE EACH	ORDER NO.	PRICE EACH
24Q	1379	1	3102-321	\$274.05	-	-
36O	1379	1	3102-322	274.05	-	-
54M	1379	1	3102-324	274.05	-	-

Carton quantity discount does not apply

Large 20 Inch Diameter Surface Grinding Wheels For Horizontal Spindle, Rotary and Reciprocating Tables.

83A – Friable Full Premium

Aluminum Oxide

Friable grain for fast stock removal. The free cutting open structure is ideal for all tool steels. V18 – Normal structures. V18P – Induced open porosity.

73C – Silicon Carbide

For non-ferrous metals, gray iron.

91A – Semi-Friable, Mixed Aluminum Oxide

A mixture of WA and A abrasives. Recommended for general purpose work and light stock removal.

AS3 – Synthetic Ceramic Blend

Features a blend of synthetic ceramic grain with PA and WA grains for optimum fracturing. Provides a continuous, sharp cutting action.



20 x 1 x 8

GRAIN	GRIT/ BOND	MAX RPM	ORDER NO.	PRICE EACH
83A	46H8 V18	1241	3280-402	\$115.80
83A	60J8 V18	1241	3280-404	115.80

20 x 1 x 10

GRAIN	GRIT/ BOND	MAX RPM	ORDER NO.	PRICE EACH
83A	36J8 V18	1241	3280-410	\$ 110.30

20 x 1-1/2 x 8

Recessed 1/S 11-1/2 x 1/2"

GRAIN	GRIT/ BOND	MAX RPM	ORDER NO.	PRICE EACH
83A	46H8 V18	1241	3280-422	\$156.55
83A	60J8 V18	1241	3280-424	156.55

20 x 1-1/2 x 10

GRAIN	GRIT/ BOND	MAX RPM	ORDER NO.	PRICE EACH
83A	46H8 V18	1241	3280-432	\$141.80

20 x 2 x 8

Recessed 2/S 11-1/2 x 1/2"

GRAIN	GRIT/ BOND	MAX RPM	ORDER NO.	PRICE EACH
83A	46H8 V18	1241	3280-442	\$194.60
83A	60J8 V18	1241	3280-446	194.60
83A	36J/K V18P	1241	3280-448	194.60
83A	46G+ V18P	1241	3280-449	194.60
91A	46I8 V18	1241	3280-440	190.65

20 x 2 x 10

GRAIN	GRIT/ BOND	MAX RPM	ORDER NO.	PRICE EACH
83A	36J8 V18	1241	3280-450	\$175.70
83A	46H8 V18	1241	3280-452	175.70
83A	60J8 V18	1241	3280-454	175.70
83A	46G+ V18P	1241	3280-456	175.70

20 x 3 x 8

Recessed 2/S 11-1/2 x 1/2"

GRAIN	GRIT/ BOND	MAX RPM	ORDER NO.	PRICE EACH
83A	46H8 V18	1241	3280-462	\$274.15
83A	36J/K V18P	1241	3280-464	274.15
83A	46D V18P	1241	3280-465	274.15
83A	46G+ V18P	1241	3280-468	274.15
91A	46I8 V18	1241	3280-460	267.85
73C	46I8 VX	1241	3280-606	351.35

20 x 3 x 10

Recessed 1/S 12-1/2 x 5/8"
O/S 12-1/2 x 1"

GRAIN	GRIT/ BOND	MAX RPM	ORDER NO.	PRICE EACH
83A	46H8 V18	1241	3280-472	\$244.20
83A	60J8 V18	1241	3280-473	244.20
83A	36J/K V18P	1241	3280-474	244.20
83A	46D V18P	1241	3280-476	244.20
83A	46G+ V18P	1241	3280-478	244.20
91A	46I8 V18	1241	3280-470	244.20
73C	46I8 VX	1241	3280-608	312.20
AS3	46H VCER	1241	3280-664	532.05

20 x 4 x 8

Recessed 2/S 11-1/2 x 1/2"

GRAIN	GRIT/ BOND	MAX RPM	ORDER NO.	PRICE EACH
83A	46H8 V18	1241	3280-482	\$362.40
83A	36J/K V18P	1241	3280-484	362.40
83A	46G+ V18P	1241	3280-488	362.40

20 x 4 x 10

Recessed 1/S 12-1/2 x 7/8"
O/S 12-1/2 x 1-1/4"

GRAIN	GRIT/ BOND	MAX RPM	ORDER NO.	PRICE EACH
83A	46H8 V18	1241	3280-492	\$326.95
83A	36J/K V18P	1241	3280-494	326.95
83A	46G+ V18P	1241	3280-498	326.95
91A	46I8 V18	1241	3280-490	304.85

20 x 6 x 10

Recessed 1/S 12-1/2 x 1"
O/S 12-1/2 x 2"

GRAIN	GRIT/ BOND	MAX RPM	ORDER NO.	PRICE EACH
83A	46H8 V18	1241	3280-502	\$435.15
83A	36J/K V18P	1241	3280-504	435.15
83A	46G+ V18P	1241	3280-508	435.15
91A	46I8 V18	1241	3280-500	414.45
73C	46I8 VX	1241	3280-614	614.45
AS3	46H VCER	1241	3280-674	804.70

20 x 6 x 12

Recessed 2/S 14-1/4 x 1"

GRAIN	GRIT/ BOND	MAX RPM	ORDER NO.	PRICE EACH
83A	46H8 V18	1241	3280-512	\$449.05
83A	36J/K V18P	1241	3280-514	449.05
83A	46G+ V18P	1241	3280-518	449.05
91A	46I8 V18	1241	3280-510	437.20

20 x 8 x 12

Recessed 2/S 14-1/2 x 1"

GRAIN	GRIT/ BOND	MAX RPM	ORDER NO.	PRICE EACH
83A	46H8 V18	1241	3280-522	\$520.40

Centerless & Cylindrical Wheels



1

12" Through 24" Diameter

Centerless & Cylindrical Wheels each have accurate toleranced inside linings to protect spindles. Manufactured with varying hardness to assure consistent grindability throughout.

94A – Aluminum Oxide
Very durable self-dressing grain.

72C – Silicon Carbide
For non-ferrous metals.

PA – Pink Aluminum Oxide
Excellent for pre-hardened carbon steels.



12 x 4 x 5 – No Recess

GRAIN	GRIT	MAX RPM	ORDER NO.	PRICE EACH
94A	60L5	2190	3327-006	\$140.15

14 x 1 x 5 – No Recess

GRAIN	GRIT	MAX RPM	ORDER NO.	PRICE EACH
94A	54K5	1910	3327-012	\$53.95
94A	60L5	1910	3327-016	53.95
94A	80M6	1910	3327-020	53.95

14 x 1-1/4 x 5 – No Recess

GRAIN	GRIT	MAX RPM	ORDER NO.	PRICE EACH
94A	54K5	1910	3327-032	\$67.55
94A	60L5	1910	3327-036	67.55

14 x 1-1/2 x 5 – Rec 1/8 X 1/2"

GRAIN	GRIT	MAX RPM	ORDER NO.	PRICE EACH
94A	54K5	1910	3327-052	\$82.50
94A	60L5	1910	3327-056	82.50
94A	80M6	1910	3327-060	82.50

14 x 2 x 5 – Rec 1/8 X 1"

GRAIN	GRIT	MAX RPM	ORDER NO.	PRICE EACH
94A	54K5	1910	3327-072	\$103.80
94A	60L5	1910	3327-076	103.80
94A	80M6	1910	3327-080	103.80

16 x 1 x 5 – No Recess

GRAIN	GRIT	MAX RPM	ORDER NO.	PRICE EACH
94A	60L5	1640	3327-096	\$77.45
94A	80M6	1640	3327-100	77.45

16 x 1-1/2 x 5 – No Recess

GRAIN	GRIT	MAX RPM	ORDER NO.	PRICE EACH
94A	60L5	1640	3327-116	\$95.85
94A	80M6	1640	3327-120	95.85

16 x 2 x 5 – No Recess

GRAIN	GRIT	MAX RPM	ORDER NO.	PRICE EACH
94A	60L5	1640	3327-156	\$118.00
94A	80M6	1640	3327-160	118.00

16 x 1 x 8 – No Recess

GRAIN	GRIT	MAX RPM	ORDER NO.	PRICE EACH
94A	54K5	1640	3327-192	\$74.35
94A	60L5	1640	3327-196	74.35
94A	80M6	1640	3327-200	74.35

16 x 1-1/2 x 8 – No Recess

GRAIN	GRIT	MAX RPM	ORDER NO.	PRICE EACH
94A	54K5	1640	3327-212	\$92.15
94A	60L5	1640	3327-216	92.15
94A	80M6	1640	3327-220	92.15

16 x 2 x 8 – No Recess

GRAIN	GRIT	MAX RPM	ORDER NO.	PRICE EACH
94A	54K5	1640	3327-232	\$111.35
94A	60L5	1640	3327-236	111.35

16 x 4 x 10 – No Recess

GRAIN	GRIT	MAX RPM	ORDER NO.	PRICE EACH
94A	60L5	1640	3327-256	\$193.20
94A	80L6	1640	3327-260	193.20

20 x 1 x 12 – No Recess

GRAIN	GRIT	MAX RPM	ORDER NO.	PRICE EACH
94A	60K5	1623	3327-276	\$90.15
94A	60L5	1623	3327-278	90.15
94A	60M6	1623	3327-280	90.15
94A	80-06	1623	3327-304	90.15

20 x 2 x 12 – No Recess

GRAIN	GRIT	MAX RPM	ORDER NO.	PRICE EACH
94A	60K5	1623	3327-316	\$141.35
94A	60L5	1623	3327-318	141.35
94A	60M6	1623	3327-320	141.35
94A	80M6	1623	3327-326	141.35
94A	80-06	1623	3327-334	141.35
94A	80-P6	1623	3327-336	141.35

HARD SIDE				
94A	80N6/120S	1623	3327-330	152.75

20 x 2-1/2 x 12 – No Recess

GRAIN	GRIT	MAX RPM	ORDER NO.	PRICE EACH
HARD SIDE				
94A	80N6/120S	1623	3327-360	\$190.65

20 x 3 x 12 – No Recess

GRAIN	GRIT	MAX RPM	ORDER NO.	PRICE EACH
94A	60K5	1623	3327-376	\$198.25
94A	60L5	1623	3327-378	198.25

20 x 4 x 12 – No Recess

GRAIN	GRIT	MAX RPM	ORDER NO.	PRICE EACH
94A	60K5	1623	3327-436	\$258.15
94A	60L5	1623	3327-438	258.15
94A	60M6	1623	3327-440	258.15
94A	80M6	1623	3327-448	258.15
94A	80-P6	1623	3327-458	258.15

HARD SIDE				
94A	80N6/120S	1623	3327-452	279.00

20 x 6 x 12 – No Recess

GRAIN	GRIT	MAX RPM	ORDER NO.	PRICE EACH
72C	60L6	1623	3327-470	\$479.00
94A	60K5	1623	3327-476	353.85
94A	60L5	1623	3327-478	353.85
94A	60M6	1623	3327-480	353.85
94A	80J5	1623	3327-484	353.85
94A	80L5	1623	3327-486	353.85
94A	80M6	1623	3327-488	353.85
94A	80-06	1623	3327-496	353.85
94A	80-P6	1623	3327-498	353.85

HARD SIDE				
94A	80N6/120S	1623	3327-492	393.95

20 x 8 x 12 – No Recess

GRAIN	GRIT	MAX RPM	ORDER NO.	PRICE EACH
72C	60L6	1623	3327-510	\$583.00
94A	54J5	1623	3327-512	454.70
94A	60K5	1623	3327-516	454.70
94A	60L5	1623	3327-518	454.70
94A	60M6	1623	3327-520	454.70
94A	80J5	1623	3327-524	454.70
94A	80L5	1623	3327-526	454.70
94A	80M6	1623	3327-528	454.70
94A	80-06	1623	3327-536	454.70

HARD SIDE				
94A	80N6/120S	1623	3327-532	504.25

20 x 10 x 12 – No Recess

GRAIN	GRIT	MAX RPM	ORDER NO.	PRICE EACH
94A	60L5	1623	3327-558	\$616.60

Centerless & Cylindrical Wheels



24 x 1-1/2 x 12 - No Recess

GRAIN	GRIT	MAX RPM	ORDER NO.	PRICE EACH
94A	60K5	1323	3327-616	\$242.55

24 x 3 x 12 - Rec 1/S 14-1/2 x 1"

GRAIN	GRIT	MAX RPM	ORDER NO.	PRICE EACH
94A	60K5	1323	3327-776	\$311.00

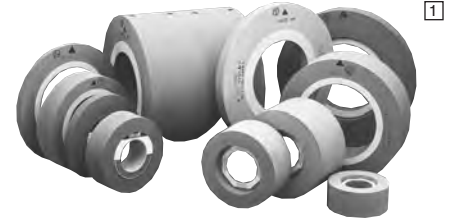

24 x 2 x 12 - No Recess

GRAIN	GRIT	MAX RPM	ORDER NO.	PRICE EACH
94A	60K5	1323	3327-656	\$242.55
94A	60L5	1323	3327-658	242.55
94A	60M6	1323	3327-660	242.55
-	-	-	-	-
94A	80-06	1323	3327-676	242.55
HARD SIDE				
94A	80N6/120S	1323	3327-672	277.30

24 x 4 x 12 - No Recess

GRAIN	GRIT	MAX RPM	ORDER NO.	PRICE EACH
94A	60K5	1323	3327-816	\$400.70
94A	60L5	1323	3327-818	400.70
-	-	-	-	-
-	-	-	-	-
94A	80M6	1323	3327-830	400.70
-	-	-	-	-
HARD SIDE				
94A	80N6/120S	1323	3327-834	445.15

24 x 8 x 12 - No Recess

GRAIN	GRIT	MAX RPM	ORDER NO.	PRICE EACH
72C	60L6	1323	3327-900	\$886.35
94A	60K5	1323	3327-916	707.40
94A	60L5	1323	3327-918	707.40
94A	60M6	1323	3327-920	707.40
94A	80J5	1323	3327-924	707.40
94A	80L5	1323	3327-928	707.40

24 x 2-1/2 x 12 - No Recess

GRAIN	GRIT	MAX RPM	ORDER NO.	PRICE EACH
HARD SIDE				
94A	80N6/120S	1323	3327-712	\$300.95

24 x 6 x 12 - No Recess

GRAIN	GRIT	MAX RPM	ORDER NO.	PRICE EACH
72C	60L6	1323	3327-850	\$677.55
94A	60K5	1323	3327-866	542.55
94A	60L5	1323	3327-868	542.55
94A	60M6	1323	3327-870	542.55
94A	80J5	1323	3327-874	542.55
-	-	-	-	-
94A	80M6	1323	3327-880	542.55
-	-	-	-	-
HARD SIDE				
94A	80N6/120S	1323	3327-884	586.25

24 x 10 x 12 - No Recess

GRAIN	GRIT	MAX RPM	ORDER NO.	PRICE EACH
94A	60K5	1323	3327-956	\$951.65
94A	60L5	1323	3327-958	951.65
94A	60M6	1323	3327-960	951.65

24 x 3 x 12 - No Recess

GRAIN	GRIT	MAX RPM	ORDER NO.	PRICE EACH
94A	60K5	1323	3327-736	\$296.70
-	-	-	-	-
-	-	-	-	-
HARD SIDE				
94A	80N6/120S	1323	3327-752	330.90

24 x 20 x 12 - No Recess

GRAIN	GRIT	MAX RPM	ORDER NO.	PRICE EACH
94A	60K5	1323	3327-986	\$1977.50
94A	60L5	1323	3327-988	1977.50
94A	60M6	1323	3327-990	1977.50

Feed/Regulating Wheels

Aluminum Oxide - Rubber Bonded For All Centerless Grinding Machines
Isostatic process assures perfect gripping with standard A-80-R2-RX grade

	MAX RPM	ORDER NO.	PRICE EACH
8 x 4 x 3 R 1/S 4-1/4 x 1/2" O/S 4-1/4 x 1-1/2"	1020	3329-040	\$136.35
9 x 2 x 4	1020	3329-120	78.35
9 x 4 x 4 R 2/S 5-1/2 x 5/8"	1020	3329-140	133.45
10 x 6 x 5-1/2 R 2/S 6-1/2 x 1/2"	920	3329-260	265.00
12 x 1 x 5	800	3329-410	70.40
12 x 2 x 5	800	3329-420	122.05
12 x 2-1/2 x 5	800	3329-425	167.50
12 x 3 x 5	800	3329-430	194.25
12 x 4 x 5 R 2/S 7-1/2 x 1/2"	800	3329-442	243.00

	MAX RPM	ORDER NO.	PRICE EACH
12 x 6 x 5 R 1/S 7-1/2 x 1/2" O/S 7-1/2 x 1-1/2"	800	3329-462	\$371.70
12 x 6 x 5 R 2/S 7-1/2 x 1-1/2"	800	3329-464	371.70
12 x 8 x 5 R 1/S 7-1/2 x 1-1/2"	800	3329-480	471.75
12 x 8 x 5 R 1/S 7-1/2 x 1-1/2" O/S 7-1/2 x 2-1/2"	800	3329-482	471.75
12 x 10 x 5 R 1/S 8 x 1-1/2" O/S 8 x 2"	800	3329-502	595.00

	MAX RPM	ORDER NO.	PRICE EACH
14 x 8 x 5 R 1/S 8 x 1-1/2" O/S 8 x 2"	650	3329-682	\$630.45
14 x 8 x 5 R 1/S 8 x 1-1/2" O/S 8 x 2-1/2"	650	3329-684	630.45
14 x 20 x 5 R 2/S 8 x 1-1/2"	650	3329-802	1558.90
14 x 20 x 6 R 2/S 8-1/2 x 1-1/2"	650	3329-804	1558.90

Mounted Points

Group "A" Special Shapes

3

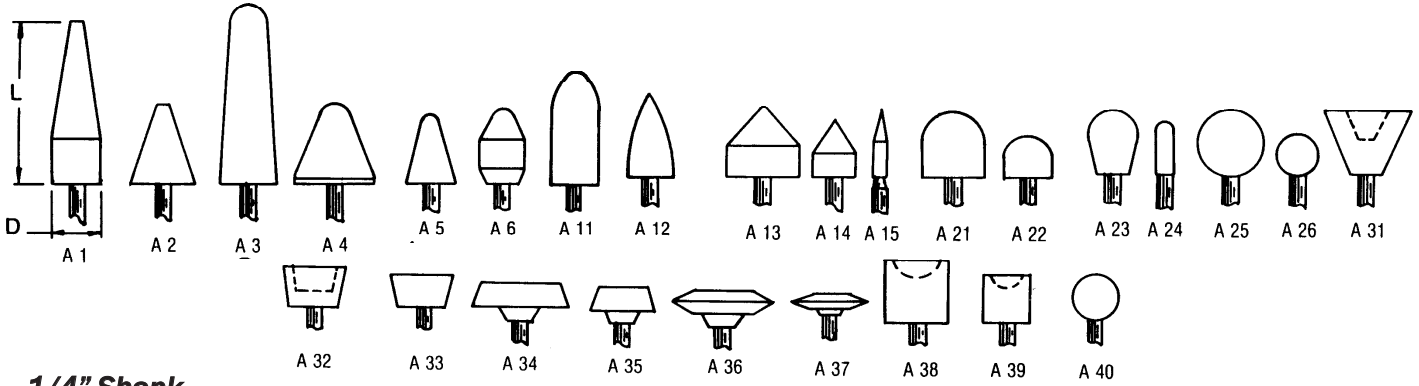

1/4" Shank

SHAPE NO.	SIZE DIAM.	LGTH.	ORDER NO.	PRICE EACH
A1	3/4"	2-1/2"	3133-001	\$2.30
A2	1"	1-1/4"	3133-002	1.40
A3	1"	2-3/4"	3133-003	2.50
A4	1-1/4"	1-1/4"	3133-004	1.60
A5	3/4"	1-1/8"	3133-005	1.35
A6	3/4"	1-1/8"	3133-006	1.35
A11	7/8"	2"	3133-011	1.70
A12	11/16"	1-1/4"	3133-012	1.35
A13	1-1/8"	1-1/8"	3133-013	1.60

SHAPE NO.	SIZE DIAM.	LGTH.	ORDER NO.	PRICE EACH
A14	11/16"	7/8"	3133-014	\$1.00
A15	1/4"	1-1/16"	3133-015	1.30
A21	1"	1"	3133-021	1.10
A22	3/4"	5/8"	3133-022	1.00
A23	3/4"	1"	3133-023	1.00
A24	1/4"	3/4"	3133-024	0.90
A25	1"	1"	3133-025	1.10
A26	5/8"	5/8"	3133-026	1.00
A31	1-3/8"	1"	3133-031	1.35

SHAPE NO.	SIZE DIAM.	LGTH.	ORDER NO.	PRICE EACH
A32	1"	5/8"	3133-032	\$1.00
A33	1"	1/2"	3133-033	1.00
A34	1-1/2"	3/8"	3133-034	1.15
A35	1"	3/8"	3133-035	1.00
A36	1-5/8"	3/8"	3133-036	1.35
A37	1-1/4"	1/4"	3133-037	1.00
A38	1"	1"	3133-038	0.90
A39	3/4"	3/4"	3133-039	0.75
A40	3/4"	3/4"	3133-040	1.00

Group "W" Plain Shapes

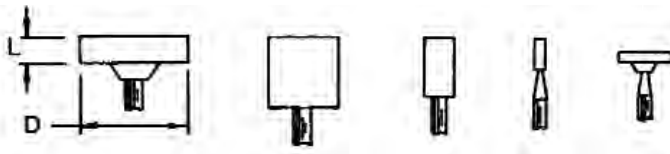

1/8" X 1-1/2" Shank

SHAPE NO.	SIZE DIAM.	LGTH.	ORDER NO.	PRICE EACH
W141	3/32	5/32	3133-141	\$0.65
W142	3/32	1/4	3133-142	0.65
W143	1/8	1/8	3133-143	0.65
W144	1/8	1/4	3133-144	0.65
W145	1/8	3/8	3133-145	0.70
W146	1/8	1/2	3133-146	0.70
W149	5/32	1/4	3133-149	0.65
W150	3/16	1/16	3133-150†	0.65
W151	3/16	1/8	3133-151	0.65
W152	3/16	1/4	3133-152	0.65
W153	3/16	3/8	3133-153	0.70
W154	3/16	1/2	3133-154	0.70
W155	13/64	1/4	3133-155†	0.65
W157	1/4	1/16	3133-157	0.65
W158	1/4	1/8	3133-158	0.65
W159	1/4	3/16	3133-159	0.65
W160	1/4	1/4	3133-160	0.65
W161	1/4	5/16	3133-161	0.70
W162	1/4	3/8	3133-162	0.70
W163	1/4	1/2	3133-163	0.70
W164	1/4	3/4	3133-164	0.75
W165	5/16	1/16	3133-165	0.65
W166	5/16	1/8	3133-166	0.65
W167	5/16	1/4	3133-167	0.65
W168	5/16	5/16	3133-168	0.70
W169	5/16	3/8	3133-169	0.70
W170	5/16	1/2	3133-170	0.70
W171	5/16	3/4	3133-171	0.75
W172	3/8	1/16	3133-172	0.65
W173	3/8	1/8	3133-173	0.65
W174	3/8	1/4	3133-174	0.65

SHAPE NO.	SIZE DIAM.	LGTH.	ORDER NO.	PRICE EACH
W175	3/8	3/8	3133-175	\$0.70
W176	3/8	1/2	3133-176	0.70
W177	3/8	3/4	3133-177	0.75
W178	3/8	1	3133-178	0.80
W179	3/8	1-1/4	3133-179†	1.05
W181	1/2	1/16	3133-181	0.65
W182	1/2	1/8	3133-182	0.65
W183	1/2	1/4	3133-183	0.65
W184	1/2	3/8	3133-184	0.65
W185	1/2	1/2	3133-185	0.70
W186	1/2	3/4	3133-186	0.75
W187	1/2	1	3133-187	0.80
W190	5/8	1/16	3133-190	0.70
W191	5/8	1/8	3133-191	0.70
W192	5/8	1/4	3133-192	0.70
W193	5/8	3/8	3133-193	0.75
W194	5/8	1/2	3133-194	0.75
W195	5/8	3/4	3133-195	0.80
W199	3/4	1/16	3133-199	0.70
W200	3/4	1/8	3133-200	0.70
W201	3/4	1/4	3133-201	0.70
W202	3/4	3/8	3133-202	0.75
W203	3/4	1/2	3133-203	0.75
W204	3/4	3/4	3133-204	0.80
W210	7/8	1/16	3133-210	0.75
W211	7/8	1/8	3133-211	0.75
W212	7/8	1/4	3133-212	0.75
W213	7/8	3/8	3133-213	0.80
W214	15/16	1/4	3133-214	0.75
W215	1	1/8	3133-215	0.75
W216	1	1/4	3133-216	0.75

1/4" X 1-1/2" Shank

SHAPE NO.	SIZE DIAM.	LGTH.	ORDER NO.	PRICE EACH
W178	3/8	1	3133-378	\$0.80
W187	1/2	1	3133-387	0.80
W188	1/2	1-1/2	3133-188	1.25
W189	1/2	2	3133-189	1.55
W194	5/8	1/2	3133-394	0.75
W195	5/8	3/4	3133-395	0.80
W196	5/8	1	3133-196	0.90
W197	5/8	2	3133-197	1.65
W198	5/8	2-1/2	3133-198	2.00
W204	3/4	3/4	3133-404	0.80
W205	3/4	1	3133-205	0.90
W206	3/4	1-1/4	3133-206	1.10
W207	3/4	1-1/2	3133-207	1.30
W208	3/4	2	3133-208	1.65
W209	3/4	2-1/2	3133-209	2.00
W213	7/8	3/8	3133-413	0.80
W217	1	3/8	3133-217	0.80
W218	1	1/2	3133-218	0.80
W219	1	3/4	3133-219	0.90
W220	1	1	3133-220	1.00
W221	1	1-1/2	3133-221	1.35
W222	1	2	3133-222	1.70
W223	1	2-1/2	3133-223	2.10
W224	1	3	3133-224	2.40
W225	1-1/4	1/4	3133-225	0.90
W226	1-1/4	3/8	3133-226	1.00
W227	1-1/4	1/2	3133-227	1.00
W228	1-1/4	3/4	3133-228	1.05
W229	1-1/4	1	3133-229	1.20
W230	1-1/4	1-1/4	3133-230	1.35
W231	1-1/4	1-1/2	3133-231	1.65
W232	1-1/4	2	3133-232	2.00
W235	1-1/2	1/4	3133-235	1.00
W236	1-1/2	1/2	3133-236	1.05
W237	1-1/2	1	3133-237	1.25
W238	1-1/2	1-1/2	3133-238	1.70
W239	1-1/2	2	3133-239	2.10
W242	2	1	3133-242	1.55
W243	2	1-1/2	3133-243	2.10
W244	2	2	3133-244	2.60
W245	2	2-1/2	3133-245†	3.15

† Limited Quantities

Mounted Points

Group "B" Special Shapes

3

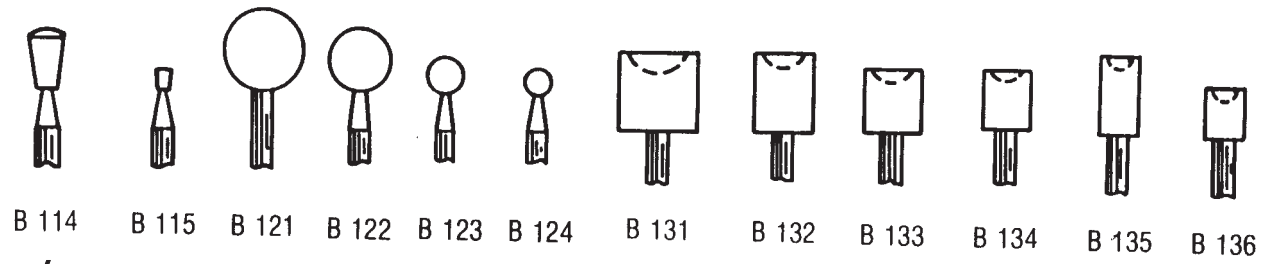
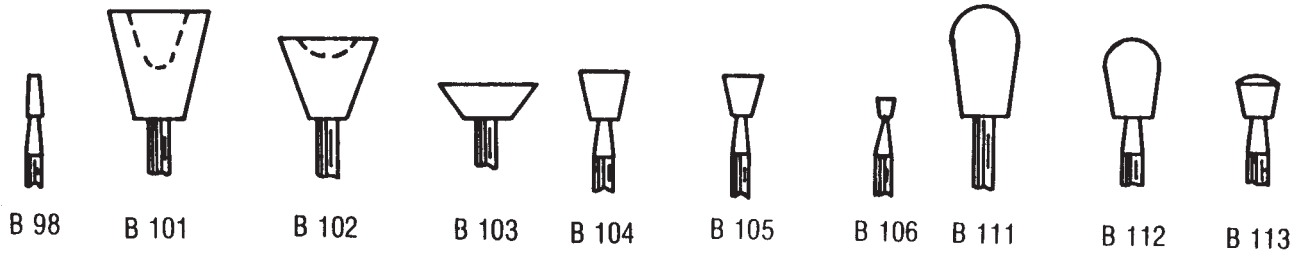
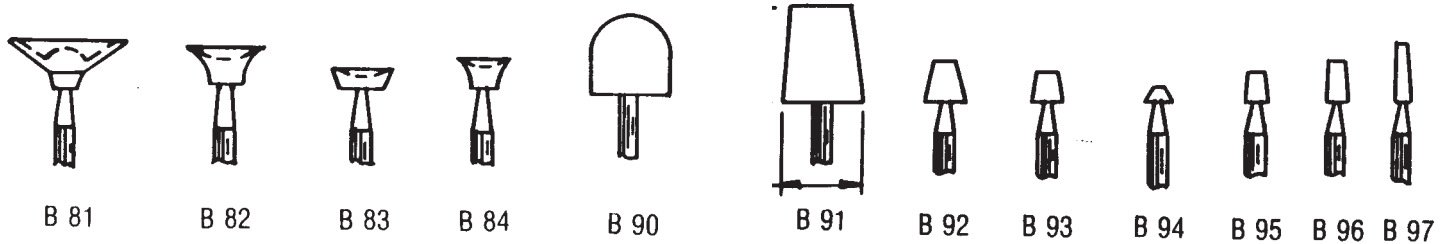
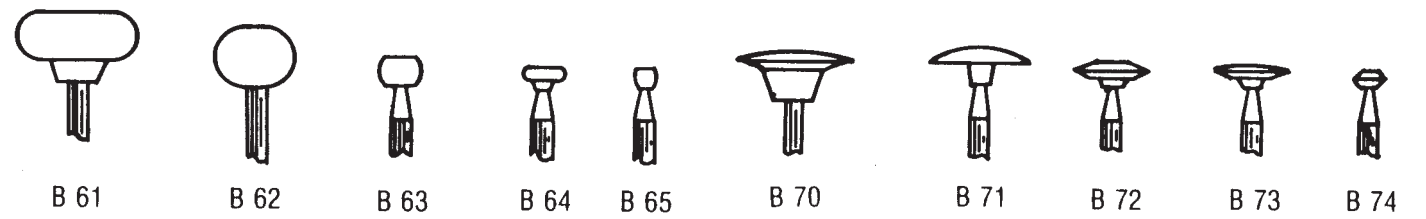
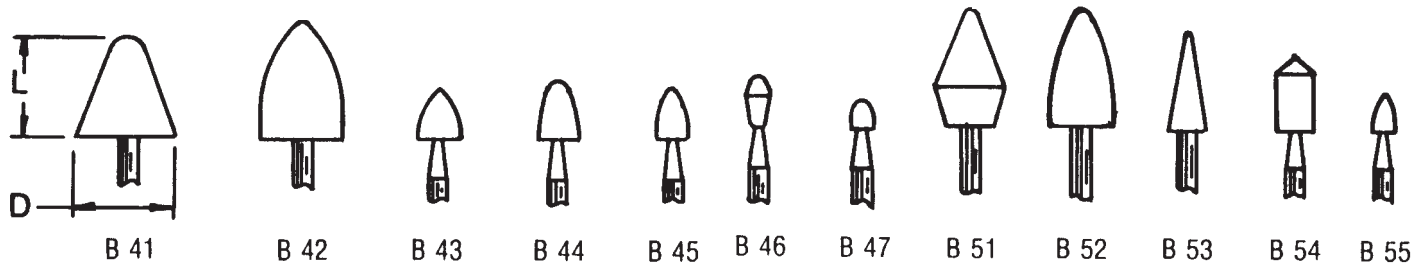

1/8" Shank

SHAPE NO.	SIZE DIAM.	LGTH.	ORDER NO.	PRICE EACH	SHAPE NO.	SIZE DIAM.	LGTH.	ORDER NO.	PRICE EACH	SHAPE NO.	SIZE DIAM.	LGTH.	ORDER NO.	PRICE EACH	SHAPE NO.	SIZE DIAM.	LGTH.	ORDER NO.	PRICE EACH
B41	5/8"	5/8"	3133-041	\$1.00	B63	1/4"	3/16"	3133-063	\$0.75	B92	1/4"	1/4"	3133-092	\$0.75	B112	3/8"	1/2"	3133-112	\$0.85
B42	1/2"	3/4"	3133-042	0.90	B64	1/4"	1/16"	3133-064	0.75	B93	3/16"	3/16"	3133-093	0.75	B113	1/4"	1/4"	3133-113	0.75
B43	1/4"	5/16"	3133-043	0.85	B65	1/8"	1/8"	3133-065	0.75	B94	11/64"	3/32"	3133-094	0.75	B114	7/32"	3/8"	3133-114	0.85
B44	7/32"	5/8"	3133-044	0.85	B70	3/4"	1/8"	3133-070	0.85	B95	1/8"	3/16"	3133-095	0.75	B115	3/32"	1/2"	3133-115	0.75
B45	3/16"	5/16"	3133-045	0.85	B71	5/8"	3/32"	3133-071	0.85	B96	1/8"	1/4"	3133-096	0.75	B121	1/2"	1/2"	3133-121	0.85
B46	1/8"	5/16"	3133-046	0.85	B72	1/2"	1/8"	3133-072	0.75	B97	1/8"	3/8"	3133-097	0.85	B122	3/8"	3/8"	3133-122	0.85
B47	1/8"	5/32"	3133-047	0.75	B73	1/2"	1/8"	3133-073	0.75	B98	3/32"	1/4"	3133-098	0.75	B123	3/16"	3/16"	3133-123	0.75
B51	7/16"	3/4"	3133-051	0.90	B74	7/32"	3/32"	3133-074	0.75	B101	5/8"	11/16"	3133-101	1.00	B124	1/8"	1/8"	3133-124	0.75
B52	3/8"	3/4"	3133-052	0.90	B81	3/4"	3/16"	3133-081	0.85	B102	5/8"	1/2"	3133-102	0.90	B131	1/2"	1/2"	3133-131	0.65
B53	1/4"	5/8"	3133-053	0.90	B82	1/2"	1/4"	3133-082	0.75	B103	5/8"	3/16"	3133-103	0.85	B132	3/8"	1/2"	3133-132	0.65
B54	1/4"	1/2"	3133-054	0.85	B83	3/8"	3/16"	3133-083	0.75	B104	5/16"	3/8"	3133-104	0.85	B133	3/8"	3/8"	3133-133	0.65
B55	1/8"	1/4"	3133-055	0.75	B84	5/16"	3/16"	3133-084	0.75	B105	1/4"	1/4"	3133-105	0.75	B134	5/16"	3/8"	3133-134	0.65
B61	3/4"	5/16"	3133-061	0.90	B90	1/2"	1/2"	3133-090	0.85	B106	1/8"	7/64"	3133-106	0.75	B135	1/4"	1/2"	3133-135	0.65
B62	3/8"	1"	3133-062	0.85	B91	1/2"	5/8"	3133-091	0.90	B111	7/16"	11/16"	3133-111	0.90	B136	1/4"	5/16"	3133-136	0.65

For Surface Grinders - 6 Inch Overall Length



**Preferred Grade -
Made in USA**

For machine or hand dressing of all wheels. Designed for longer tool life.

Economy Grade

For general purpose dressing and truing of soft wheels.

RECOMMENDED DIAMOND SIZE			
WHEEL FACE	CARAT WT.	WHEEL FACE	CARAT WT.
1/4	1/4	2	1-1/2
1/2	1/3	3	1-3/4
3/4	1/2	3-1/2	2
1	3/4	4	2-1/2
1-1/4	1	6	3
1-1/2	1-1/4	8 and up	3-1/2

SHANK SIZE	CARAT SIZE	ECONOMY		PREFERRED - USA	
		ORDER NO.	PRICE	ORDER NO.	PRICE
3/8	1/4	3131-311	\$ 4.30	3131-341	\$ 18.50
3/8	1/3	3131-312	6.35	3131-342	22.00
3/8	1/2	3131-313	8.70	3131-343	27.10
3/8	3/4	3131-314	12.95	3131-344	39.00
3/8	1	3131-315	17.20	-	-
3/8	1-1/2	3131-316	25.80	-	-
3/8	2	3131-317	34.20	-	-
3/8	3	3131-318	48.55	-	-
7/16	1/4	3131-321	4.30	3131-361	18.50
7/16	1/3	3131-322	6.35	3131-362	22.00
7/16	1/2	3131-323	8.70	3131-363	27.10
7/16	3/4	3131-324	12.95	3131-364	39.00
7/16	1	3131-325	17.20	-	-
7/16	1-1/2	3131-326	25.80	-	-
7/16	2	3131-327	34.20	-	-
7/16	3	3131-328	48.55	-	-
1/2	1/4	3131-331	4.30	-	-
1/2	1/3	3131-332	6.35	-	-
1/2	1/2	3131-333	8.70	-	-
1/2	3/4	3131-334	12.95	-	-
1/2	1	3131-335	17.20	-	-
1/2	1-1/2	3131-336	25.80	-	-
1/2	2	3131-337	34.20	-	-
1/2	3	3131-338	48.55	-	-

Economy - Super Value 1/4 Carat - Single Point



SHANK SIZE	ORDER NO.	PRICE
3/8 x 2	3131-040	\$4.55
3/8 x 3	3131-045	4.55
7/16 x 2	3131-080	4.55
7/16 x 3	3131-085	4.55

Convex & Concave Radii Forming Tools MR and FR Series

Designed to form convex and concave radii on small diameter grinding wheels. 3/8" x 2" Shanks.



MR Series Convex Radii

TOOL NO.	RADIUS	ORDER NO.	PRICE
MR-2	.020-.125	3131-582	\$12.45
MR-4	.125-.250	3131-584	14.00
MR-6	.250 up	3131-586	17.20



FR Series Concave Radii

TOOL NO.	RADIUS	ORDER NO.	PRICE
FR-10	.010	3131-550	\$10.00
FR-15	.015	3131-555	10.00
FR-20	.020	3131-560	10.00
FR-32	.032	3131-565	11.30
FR-62	.062	3131-570	12.90
FR-125	.125	3131-575	12.90

Coned Radius Dressers



A precision shaped tool used for intricate form & radius dressing.

CARAT SIZE	INCLUDED ANGLE	3/8 x 2-1/2 SHANK		7/16 x 2-1/2 SHANK	
		ORDER NO.	PRICE	ORDER NO.	PRICE
1/4	60 DEG	3131-461	\$44.00	3131-481	\$44.00
1/4	75 DEG	3131-462	40.00	3131-482	40.00
1/4	90 DEG	3131-463	33.75	3131-483	33.75
1/3	60 DEG	3131-464	70.00	3131-484	70.00
1/3	75 DEG	3131-465	62.00	3131-485	62.00
1/3	90 DEG	3131-466	42.65	3131-486	42.65
1/2	60 DEG	3131-467	94.00	3131-487	94.00
1/2	75 DEG	3131-468	82.00	3131-488	82.00
1/2	90 DEG	3131-469	64.00	3131-489	64.00

Phonopoint Diamond Dressing Tools

Small cone pointed tools used for precision form dressing.



SHANK SIZE	60 DEG		75 DEG		90 DEG	
	ORDER NO.	PRICE	ORDER NO.	PRICE	ORDER NO.	PRICE
1/8 x 1"	3131-536	\$6.20	3131-541	\$5.60	3131-546	\$5.10
3/16 x 1"	3131-537	6.60	3131-542	6.00	3131-547	5.40
1/4 x 1-1/2"	3131-539	7.00	3131-544	6.30	3131-549	5.50

Thread Grinding Diamond Tools



For use on Jones & Lamson, Ex-Cell-O & similar thread grinding equipment.

SIZE	MACHINE	60 DEG		90 DEG	
		ORDER NO.	PRICE	ORDER NO.	PRICE
1/4 x 1	J & L	3131-605	\$9.80	3131-607	\$9.80
3/8 x 1-5/8	EX-CELL-O	3131-615	9.80	-	-

Hand Diamond Dressers



7/16" Shank Size - 8" Overall Length

Dressers fitted with plastic handles. Ideal for dressing wheels for Surface Grinders, Universal Grinders, etc.

CARAT SIZE	ORDER NO.	PRICE
1/4	3131-451	\$6.75
1/3	3131-452	8.55
1/2	3131-453	10.75
3/4	3131-454	18.10
1	3131-455	25.65

Diamond Tools

Machine-Use Single Point Diamond Dressers

Preferred Grade Diamond

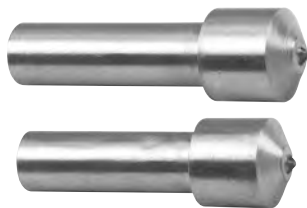

CARAT SIZE	LARGE NORTON Shank: 7/16 x 1-1/2 Head: 5/8" x 5/8"		CINCINNATI Shank: 7/16 x 2 Head: 5/8" x 5/8"	
	ORDER NO.	PRICE	ORDER NO.	PRICE
1/4	3131-391	\$18.60	3131-381	\$18.60
1/3	3131-392	22.40	3131-382	22.40
1/2	3131-393	30.00	3131-383	30.00
3/4	3131-394	44.00	3131-384	44.00
1	3131-395	60.00	3131-385	60.00
1-1/2	3131-396	95.10	3131-386	95.10

Natural & Lapped Chisels



For use on radius dressers to form radii, steps, or contours. Tools shown are 1/4 Carat.

SHANK SIZE	NATURAL CHISEL EDGE		60° LAPPED CHISEL	
	ORDER NO.	PRICE	ORDER NO.	PRICE
3/8 x 2-1/2"	3131-520	\$30.10	3131-500	\$47.30
7/16 x 2-1/2"	3131-530	30.10	3131-510	47.30

Multi Point Cluster Dressing Tools

5/8" Diameter Head, 7 Diamonds



For straight face and side dressing finishes.

CARAT SIZE	3/8 SHK	7/16 SHK	1/2 SHK	PRICE
	ORDER NO.	ORDER NO.	ORDER NO.	
1	3131-400	3131-415	3131-430	\$26.00
2	3131-405	3131-420	3131-435	34.00
3	3131-410	3131-425	3131-440	42.00

Diamond Hones

Features:

- Resin Bond. 100% Concentration.
- Diamond Length: 1"
- 3/8" width square
- Overall Length: 4"



DOUBLE END

GRIT	ORDER NO.	PRICE
100/180	3131-640	\$39.00
150/220	3131-641	39.00
180/320	3131-642	39.00
220/400	3131-643	39.00

SINGLE END

GRIT	ORDER NO.	PRICE
100	3131-644	\$27.00
150	3131-645	27.00
220	3131-646	27.00
320	3131-647	27.00
400	3131-648	27.00
600	3131-649	27.00

Diamond Wheel Dressers



SIZE	ORDER NO.	PRICE EACH
0	3131-670	\$7.40
1	3131-671	8.35
2	3131-672	13.05

Cutters For Diamond Wheel Dressers



SIZE	ORDER NO.	PRICE EACH
0	3131-675	\$1.55
1	3131-676	2.35
2	3131-677	4.65

T-Handle Diamond Dressers



Used for hand truing and dressing. A broad, flat surface of diamonds in a matrix. 3/8" x 6" Shank. 1/2" W x 1-1/2" L head. 6-1/2" OAL.

GRADE	NO. OF DIAMONDS	ORDER NO.	PRICE
Standard	28	3131-591	\$80.00
Medium	38	3131-592	88.00
Heavy Duty	48	3131-593	96.00

Diamond Wheels

Straight Diamond Wheels – Type D1A1

Resin Bond, With Diamonds in Periphery
1/8" Diamond Depth, 150 Grit

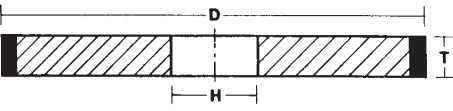

75 Concentration – Economical Grinding
100 Concentration – For Surface Grinding. Longer life.

D DIAM.	T THICKNESS	H HOLE DIAM.	75 CONCENTRATION		100 CONCENTRATION	
			150 GRIT ORDER NO.	PRICE	150 GRIT ORDER NO.	PRICE
4	1/8	1-1/4	–	–	3130-128	\$ 78.25
4	1/4	1-1/4	–	–	3130-148	110.00
5	1/8	1-1/4	–	–	3130-228	85.35
5	1/4	1-1/4	–	–	3130-248	125.00
6	1/8	1-1/4	3130-323	\$ 86.25	3130-328	106.50
6	1/4	1-1/4	3130-343	111.10	3130-348	135.50
6	3/8	1-1/4	3130-363	150.50	3130-368	170.00
6	1/2	1-1/4	3130-383	158.25	3130-388	210.00
7	1/8	1-1/4	–	–	3130-428	138.00
7	1/4	1-1/4	3130-443	133.35	3130-448	170.00
7	3/8	1-1/4	–	–	3130-468	191.50
7	1/2	1-1/4	–	–	3130-488	232.00
8	1/4	1-1/4	–	–	3130-548	208.00
8	1/2	1-1/4	–	–	3130-588	252.00

Other Grits, Diamond Depths and Arbor Hole Diameters available.

Diamond Cut-Off Wheels – Type D1A1R

Resin Bond, 100% Concentration, 1/4" Depth

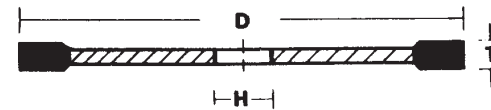

For cutting-off on Carbide.

D DIAM.	T THICKNESS	H HOLE DIAM.	GRIT	ORDER NO.	PRICE
6	.035	1-1/4	150	3130-910	\$ 84.45
6	.045	1-1/4	150	3130-915	103.10

Diamond Face Wheels – Type D6A2C

Resin Bond, Plate Mounted, 150 Grit

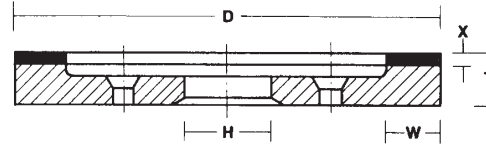

For Carbide Tool Grinders. Bolt holes countersunk for maximum safety.

D DIAM.	T THICKNESS	H HOLE DIAM.	W RIM WIDTH	X DIAMOND DEPTH	CONCN.	ORDER NO.	PRICE
6	3/4	1-1/4	1/2	1/8	75%	3130-953	\$161.00
6	3/4	1-1/4	1/2	1/8	100%	3130-958	184.00
6	3/4	1-1/4	3/4	1/16	75%	3130-963	97.80
6	3/4	1-1/4	3/4	1/16	100%	3130-968	183.00
6	1	1-1/4	3/4	1/16	75%	3130-983	131.00

Diamond Flaring Cup Wheels – Type D11V9

Resin Bond Diamond in the periphery and on the face.
Grind with face only.

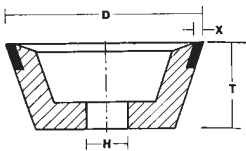

For use with Tool & Cutter Grinders.

D DIAM.	T THICKNESS	H HOLE DIAM.	X DIAMOND DEPTH	CONCN.	100 GRIT ORDER NO.	150 GRIT ORDER NO.	PRICE
3-3/4	1-1/2	1-1/4	1/8	75%	3129-121	3129-123	\$ 99.60
3-3/4	1-1/2	1-1/4	1/8	100%	3129-126	3129-128	112.00
5	1-3/4	1-1/4	1/8	75%	3129-221	3129-223	114.70
5	1-3/4	1-1/4	1/8	100%	3129-226	3129-228	126.25

Diamond Dish Wheels – Type D12A2

Resin Bond. Diamond on the face (rim).
100% Concentration, 150 Grit

T THICKNESS	H HOLE DIAM.	B DISH ANGLE	E BACK THICKNESS	K INSIDE FLAT	X DIAMOND DEPTH
1"	1-1/4	30	1/2	2-5/8	1/8

Used for sharpening Cutting Tools.

D DIAMETER	W RIM WIDTH	ORDER NO.	PRICE
6	3/16	3129-358	\$129.00
6	1/4	3129-368	142.00
6	3/8	3129-378	189.00

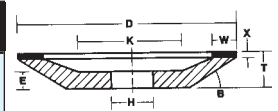

Diamond Flaring Cup Wheels – Type D11A2

Resin Bond. Diamond on the face (rim).
100% Concentration, 150 Grit

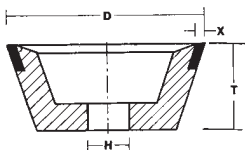

For use with Tool & Cutter Grinders.

D DIAM.	T THICKNESS	H HOLE DIAM.	W RIM WIDTH	X DIAMOND DEPTH	ORDER NO.	PRICE
3	7/8	1-1/4	3/8	1/8	3129-308	\$105.40
4	1-1/4	1-1/4	1/2	1/8	3129-318	129.00
5	1-3/4	1-1/4	3/8	1/8	3129-328	150.50

5 Inch Diamond Facewheels – 5" x 1/4" x 3"

Resin Bond, Steel Core, 100% Concentration

For Leonard, Cold Grind and similar type grinders.

STANDARD SECTION	120 GRIT ORDER NO.	220 GRIT ORDER NO.	320 GRIT ORDER NO.	PRICE
1/32	3129-407	3129-409	3129-412	\$172.00
1/16	3129-427	3129-429	3129-432	189.00



Diamond Wheel Cleaning Stick Vitrified Bond Aluminum Oxide

For cleaning CBN and Diamond Wheels.

SIZE	GRADE	ORDER NO.	PRICE
4 x 1/2 x 1/2	150I	3129-054	\$2.55
4 x 3/4 x 3/4	150I	3129-064	2.80
6 x 3/4 x 3/4	150I	3129-066	4.55



Optical Radius Angle Dresser

Visual Universal Wheel Dresser

Adaptable to surface grinders and universal tool grinders. 3X lens magnification through the spindle allows the operator to view the diamond point for radii and angle forming. Easy and accurate.

Order No. 3131-684

Price: ...\$377.90



SPECIFICATIONS	
Center Height	2.5"
Max. Wheel Diameter	8"
Max. Convex Radius	1/2"
Max. Concave Radius	1"
Dressing Angle	90 - 0 - 90 (1 deg incr)
Tangential Travel	.89" either side
Mounting Surface	3.27 x 1.87"
Overall Length	8.39"
Overall Height	3.94"

- Accuracy to 0.0001"
- Gauge block setting
- Radius and angle can be done perfectly tangent
- Compact design
- Wt. 7.7 lbs.
- Complete with Diamond Dressers, Hex Keys and Wood Case.

Precision Punch Former & Radius Wheel Dresser

For grinding wheel and punch forming applications. Concave and Convex radii. Hardened tool steel construction. Fitted case.

Order No. 3131-686

Price: ...\$672.00

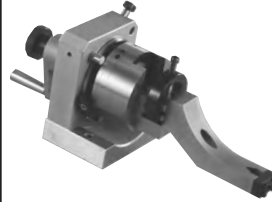

SPECIFICATIONS	
Max. Dia. - Workpiece	1-1/4"
V-Block	1-3/16"
Adjusting System	Rack and Pinion
Center Height	3-1/2"
Indexing Divisions	24 every 15 Degree +/-10 seconds
Angle Setting	By sine system
Roundness	0.0001"
Parallelism	w/i 0.0001" in 4"
Squareness	w/i 0.0002" in 4"
Graduation	360 Deg.
Weight	17.0 lbs.

Radius and Angle Dresser

For use on all OD, ID and surface grinding applications.

No height gage or set-up aids required. Radius is set on the grinder by measuring over the two pins or by inserting a gage block, for direct reading. Inside or outside radius is determined by using either the left hand or right hand pins. Uses 3/8" shank diamond tool.

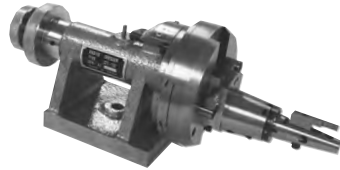

Order No. 3131-687 Price: ...\$311.40

SPECIFICATIONS			
Max. Wheel Diameter	12"	Center Line Of Tool	3.4"
Max. Convex Radii	0 to 1-5/8"	Overall Length	16-5/8"
Max. Concave Radii	0 to 4"	Weight	30 lbs.
Tangent Travel	2"	Accuracy	.0005"

Profile Wheel Dresser

Accurate and versatile Radius and Angle Wheel Dresser. *Fast and easy set-ups without elaborate accessories. Only a micrometer and hex key wrench are needed. *Dress 2 angles tangent to a radius in one continuous motion to within .0001". *Precise and sharp contours, concave and convex, are consistently obtained at a full 180 Degree range.

Order No. 3131-685

Price: ...\$492.00

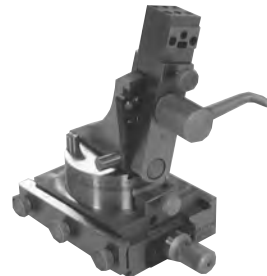

SPECIFICATIONS	
Max. Dia. - Workpiece	8"
Convex Radii	0 to 1-1/2"
Concave Radii	.030 to 1-1/2"
Center Height	3-1/2"
Height to center of diamond	6-1/2"
Dia. of Setting Pins	10mm
Overall Height	7"
Base	4-3/4 x 3-1/2 x 1-1/4"

Diamond Nib Holder

Use on surface grinders. Holds Diamond Dresser at 15 Deg. angle. Base dimension: 2-1/2" x 6" Keyway: 1/2" x 7/8" Includes 7/16 x 2" 1/4 Carat dresser.

Order No. 3131-683...Price: \$21.45

Replacement Diamond Dresser

Order No. 3131-080Price:\$4.55



Low-Boy Angle Dresser

Use on all grinding machines. Base Angle-Plate heavy, precision ground, square on six sides to .0005" accuracy. Side block pivots on hardened screws. Includes 3/8 x 2 1/4 Carat dresser.

Order No. 3131-682

Price:\$76.75

Replacement Diamond Dresser-

Order No. 3131-040

Price:\$4.55

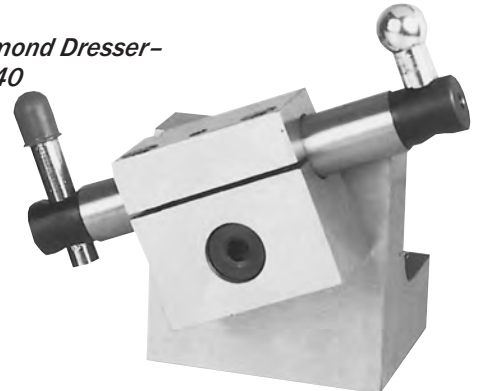

Hi-Low Adjustable Dresser

Use on all grinding machines. Dress O.D. and face of wheels. Adjustable to 7" Height. Includes 3/8 x 3" 1/4 Ct. dresser.

Order No. 3131-681

Price:\$46.00

Replacement Diamond Dresser

Order No. 3131-045

Price:\$4.55



Diamond & CBN Electro-Plated Mandrels/Jig Grinding Pins

2

Coarse Grit 80/120

Tolerance on Hardened Steel Shanks: +.0000/-.0006

Diamond plated mandrels are used for internal grinding of glass, ceramics, cemented carbides, and other hard and abrasive materials.

CBN is ideal for High Speed Steels, such as M2, M3, M7 & T16; Die Steels, such as D2, D3, HB & A&O; Alloy Steels (harder than 50Rc); Nickel and Cobalt Base Super Alloys; Titanium, and Stainless Steels.

STYLE I

A HEAD	B HEAD LENGTH	C NECK LENGTH	D SHANK SIZE	DIAMOND ORDER NO.	CBN ORDER NO.	PRICE
.020	1/16	1/8	1/8	3128-600	3126-600	\$11.00
.025	3/32	1/4	1/8	3128-601	3126-601	9.40
.030	3/32	1/4	1/8	3128-602	3126-602	9.40
.035	3/32	1/4	1/8	3128-603	3126-603	9.40
.040	1/8	3/8	1/8	3128-604	3126-604	9.40
.045	1/8	3/8	1/8	3128-605	3126-605	9.80
.050	1/8	3/8	1/8	3128-606	3126-606	9.80
.050	1/8	1	1/8	3128-607	3126-607	11.80
.055	1/8	3/8	1/8	3128-608	3126-608	9.90
.060	1/8	3/8	1/8	3128-609	3126-609	9.70
.060	1/8	1	1/8	3128-610	3126-610	11.70
.070	5/32	1/2	1/8	3128-611	3126-611	10.30
.070	5/32	1	1/8	3128-612	3126-612	11.80
.080	5/32	1/2	1/8	3128-613	3126-613	10.90
.080	5/32	1	1/8	3128-614	3126-614	12.00
.090	5/32	1/2	1/8	3128-615	3126-615	11.00
.090	5/32	1	1/8	3128-616	3126-616	12.10
.100	5/32	1/2	1/8	3128-617	3126-617	11.00
.100	5/32	1	1/8	3128-618	3126-618	12.30
.110	5/32	1/2	1/8	3128-619	3126-619	11.30
.110	5/32	1	1/8	3128-620	3126-620	12.30
.125	5/32	1/2	1/8	3128-621	3126-621	11.90
.125	5/32	1	1/8	3128-622	3126-622	13.00
.141	1/4	1	1/4	3128-623	3126-623	16.80
.156	1/4	1	1/4	3128-624	3126-624	19.40
.188	1/4	1	1/4	3128-625	3126-625	19.40
.218	1/4	1	1/4	3128-626	3126-626	19.40
.250	1/8	1	1/4	3128-627	3126-627	19.40
.250	1/4	1	1/4	3128-628	3126-628	19.40

STYLE I

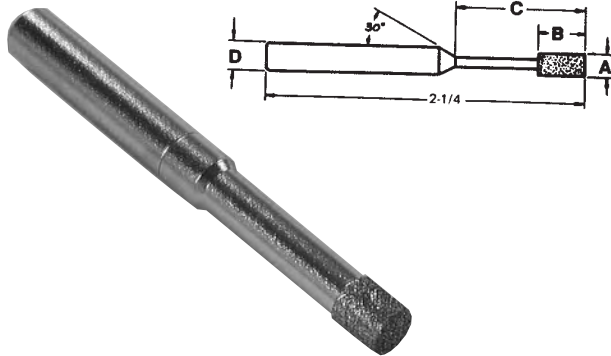

STYLE II

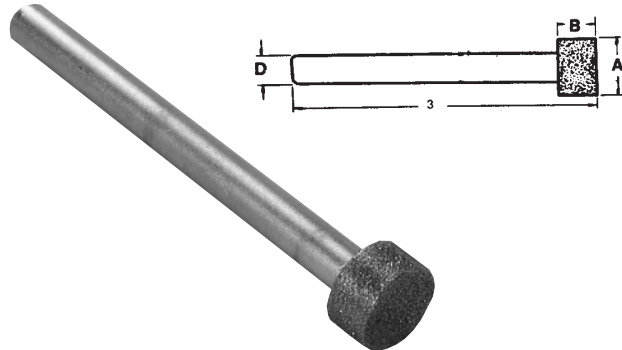

STYLE II

A HEAD	B HEAD LENGTH	D SHANK SIZE	DIAMOND ORDER NO.	CBN ORDER NO.	PRICE
.312	1/8	1/4	3128-640	3126-640	\$24.30
.312	1/4	1/4	3128-641	3126-641	27.90
.375	1/8	1/4	3128-642	3126-642	24.30
.375	1/4	1/4	3128-643	3126-643	27.90
.500	1/4	1/4	3128-644	3126-644	33.40
.500	3/8	1/4	3128-645	3126-645	33.40
.750	1/4	1/4	3128-646	3126-646	47.40
.750	1/2	1/4	3128-647	3126-647	47.40

Diamond Polishing & Lapping Compounds

2

“Universal Carrier”—

Oil or Water Soluble Stocked in 5 Gram Disposable Plastic Syringes

FINISH	COLOR	MICRON GRADE	MICRON RANGE	LIGHT CONCENTRATION		MEDIUM CONCENTRATION		HEAVY DUTY CONCENTRATION	
				ORDER NO.	PRICE	ORDER NO.	PRICE	ORDER NO.	PRICE
Super Fine	Yellow	3	1-5	3126-570	\$10.20	3126-571	\$12.90	3126-572	\$16.00
	Orange	5	4-8	3126-573	10.80	3126-574	15.00	3126-575	20.40
	Green	9	6-12	3126-576	11.80	3126-577	16.10	3126-578	21.40
Fine	Blue	15	10-22	3126-590	11.80	3126-591	16.10	3126-592	21.40
	Red	30	20-40	3126-593	11.80	3126-594	16.10	3126-595	21.40
	Brown	45	30-60	3126-596	11.80	3126-597	16.10	3126-598	21.40



Type 1 Cut-Off Wheels - Tool Room, Die Grinder

1

Buy
Std. Ctn.
Deduct
10%

CGW Tool Room Wheels

Aluminum Oxide - Resin Bonded

Reinforced: For stationary tool room and machine shop use. Fast cutting and clean finishes where precision is necessary.

Non-Reinforced: Use on fixed base cut-off machines with the work piece clamped securely and the wheel properly guarded. Fast cutting with clean finish.



CGW

Type 1 Quickie Cut™ Reinforced Rt. Angle Grinding Wheels



CGW Quickie Cut™ Reinforced Type 1 Cut-Off wheels are safe for use on Right Angle Grinders, providing excellent results on stainless steel, alloys, and ferrous. Select from B-Flex or Rigid configurations.

SIZE DIA. x THICK. x ARBOR	MAX. RPM	GRADE	STD. CTN.	ORDER NO.	PRICE EACH
6 x .040 x 1/2	10186	A60-O/P	25	3896-402†	\$1.67
6 x .040 x 5/8	10186	A60-O/P	25	3896-404†	1.67
6 x .060 x 5/8	10186	A60-O/P	25	3896-604	2.17
7 x .040 x 1/2	8732	A60-O/P	25	3897-402†	1.93
7 x .040 x 1-1/4	8732	A60-O/P	25	3897-406	2.52
7 x .060 x 1/2	8732	A60-O/P	25	3897-602†	2.02
7 x .060 x 1-1/4	8732	A60-O/P	25	3897-606	2.61
8 x .040 x 1-1/4	7640	A60-O/P	25	3898-406	3.46
8 x .060 x 1-1/4	7640	A60-O/P	25	3898-608	3.56
NON-REINFORCED					
6 x 1/32 x 5/8	7639	A60M	25	3890-230†	2.25
6 x 1/16 x 1/2	7639	A60M	25	3890-240†	2.31
6 x 1/16 x 5/8	7639	A60M	25	3890-245†	2.07
7 x 1/32 x 1-1/4	6548	A60M	25	3890-265	3.37
7 x 1/16 x 1/2	6548	A60M	25	3890-270	3.44
7 x 1/16 x 1-1/4	6548	A60M	25	3890-280	3.44
7 x 1/8 x 1/2	6548	A60M	25	3890-300†	2.88
7 x 1/8 x 1-1/4	6548	A60M	25	3890-315	4.00
8 x 1/16 x 1/2	5729	A60M	25	3890-335†	3.13
8 x 1/16 x 5/8	5729	A60M	25	3890-340†	3.13
8 x 1/16 x 1-1/4	5729	A60M	25	3890-345	4.17
8 x 1/8 x 1/2	5729	A60M	25	3890-360†	3.20
8 x 1/8 x 1-1/4	5729	A60M	25	3890-370	4.89

† Limited Quantities



Fiberglass Reinforced Aluminum Oxide - Resin Bonded

For tool room and machine shop use.

SIZE DIA. x THICK. x ARBOR	MAX. RPM	GRADE	STD. CTN.	ORDER NO.	PRICE EACH
6 x .035 x 1/2	10200	A60T	25	6556-170	\$1.79
6 x .035 x 5/8	10200	A60T	25	6556-171	1.79
7 x .035 x 5/8	8740	A60T	25	6556-183	2.04
7 x .035 x 1-1/4	8740	A60T	25	6556-184	2.04
7 x 1/16 x 5/8	8740	A36T	25	6556-188	2.14
7 x 1/16 x 1-1/4	8740	A60T	25	6556-193	2.14
8 x .035 x 1-1/4	7640	A60T	25	6556-199†	3.61

† Limited Quantities

ZAG0-TB-FLEX WHEELS					
SIZE DIA. x THICK. x ARBOR	SPEC	RPM	STD. CTN.	ORDER NO.	PRICE EACH
4 x .040 x 5/8	ZA60-TB-FLEX	19,000	25	3898-650	\$1.20
4 1/2 x .035 x 7/8	ZA60-TB-FLEX	13,300	25	3898-653	1.17
5 x .040 x 7/8	ZA60-TB-FLEX	12,250	25	3898-656	1.48
6 x .040 x 3/8	ZA60-TB-FLEX	10,200	25	3898-659	1.98
6 x .040 x 1/2	ZA60-TB-FLEX	10,200	25	3898-662	1.98
6 x .040 x 5/8	ZA60-TB-FLEX	10,200	25	3898-665	1.98
6 x .040 x 7/8	ZA60-TB-FLEX	10,200	25	3898-668	1.67
7 x 1/16 x 7/8	ZA60-TB-FLEX	8,500	25	3898-671	2.35
ZA36T RIGID WHEELS					
4 1/2 x .045 x 7/8	ZA36-T-BF	13,300	25	3890-471	1.16
5 x .045 x 7/8	ZA36-T-BF	12,250	25	3890-472	1.45
6 x .045 x 7/8	ZA36-T-BF	10,200	25	3890-473	1.64
7 x 1/16 x 7/8	ZA36-T-BF	8,500	25	3890-474	2.28
9 x 1/16 x 5/8	ZA36-T-BF	6,600	25	3890-476	4.19

Mounting Mandrels

For small diameter Type 1 Wheels

ARBOR SIZE	WHEEL THICKNESS	ORDER NO.	PRICE EACH
1/4"	.035 to 1/4	6556-489	\$6.17
3/8"	.035 to 1/4	6556-490	6.17
1/4", 3/8"	.035 to 1/4	6556-491	10.61

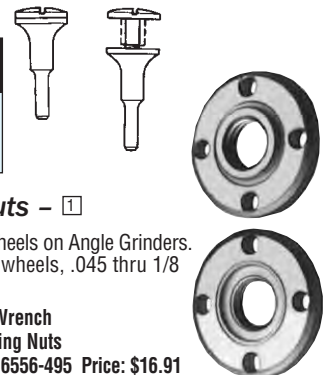

Reusable Flange Adapting Nuts - 1

For use with 4-1/2" and 5" Diameter Cutoff Wheels on Angle Grinders. Can be used with Type 1 or Type 27 Cutoff wheels, .045 thru 1/8 thickness, 7/8" Arbor Hole.

Flange Nuts - (Pr)

1-3/4" Dia. x 5/8-11 AH

Order No. 6556-494 Price: \$21.02

Spanner Wrench

For Adapting Nuts

Order No. 6556-495 Price: \$16.91

Small Diameter - Portable Grinder Fiberglass Reinforced - Aluminum Oxide - Resin Bonded

For use on air or electric straight shaft high speed right angle and die grinders. Designed for fast, burr free cutting and notching. Works especially well on thin walled tube and pipe.

CGW						WELLER TIGER				FLEXOVIT USA			
SIZE DIA. x THICK. x ARBOR	MAX. RPM	GRADE	STD. CTN.	ORDER NO.	PRICE EACH	GRADE	STD. CTN.	ORDER NO.	PRICE EACH	GRADE	STD. CTN.	ORDER NO.	PRICE EACH
3 x .035 x 1/4	24000	A60	50	3890-410*	\$0.87	A60T	100	6556-061	\$0.69	A60T	100	3893-610	\$1.76
3 x .035 x 3/8	24000	A60	50	3890-415*	0.87	A60T	100	6556-062	0.69	A60T	100	3893-615	1.76
3 x 1/16 x 1/4	24000	A36	50	3890-420	0.89	A36T	100	6556-065	0.76	A46T	50	3893-620	1.76
3 x 1/16 x 3/8	24000	A36	50	3890-425	0.89	A36T	100	6556-068	0.76	A46T	50	3893-625	1.76
3 x 1/8 x 1/4	24000	A24	50	3890-430	1.00	-	-	-	-	A36R	25	3893-630	2.47
3 x 1/8 x 3/8	24000	A24	50	3890-435	1.00	A36T	50	6556-076	0.83	A36R	25	3893-635	2.47
4 x .035 x 1/4	19000	A60	50	3890-440*	1.15	A60T	50	6556-079	0.90	A60T	100	3893-640	2.56
4 x .035 x 3/8	19000	A60	50	3890-445*	1.15	A60T	50	6556-080	0.90	A60T	100	3893-645	2.56
4 x 1/16 x 1/4	19000	A36	50	3890-450	1.24	A36T	100	6556-083	0.94	A46T	50	3893-650	2.56
4 x 1/16 x 3/8	19000	A36	50	3890-455	1.24	A36T	100	6556-086	0.94	A46T	50	3893-655	2.56
4 x 1/8 x 1/4	19000	A24	50	3890-460	1.39	-	-	-	-	A36R	25	3893-660†	2.99
4 x 1/8 x 3/8	19000	A24	50	3890-465	1.37	A36T	50	6556-099	1.18	A36R	25	3893-665	2.99
4-1/2 x .045 x 7/8	13300	-	-	-	-	A60T	100	6556-103**	1.34	A60SST	25	3893-670	2.56
5 x .045 x 7/8	12000	-	-	-	-	A36T	25	6556-118**	1.51	A60SST	25	3893675	3.26

* 1/32" Thick, ** 1/16" Thick

† Limited Quantities



Type 1 Cut-Off Wheels

1

**Buy
Std. Ctn.
Deduct
10%**

Circular Saw Wheels

Fiberglass Reinforced – Resin Bonded

Designed to meet the demands of the professional contractor. A general purpose wheel providing fast cutting action.



SIZE DIA. x THICK. x ARBOR	MAX. RPM	CGW			CGW			FLEXOVIT USA			FLEXOVIT USA		
		METAL, STAINLESS			MASONRY, CONCRETE			METAL, STAINLESS			MASONRY, CONCRETE		
		GRADE	ORDER NO.	PRICE EACH	GRADE	ORDER NO.	PRICE EACH	GRADE	ORDER NO.	PRICE EACH	GRADE	ORDER NO.	PRICE EACH
7 x 3/32 x 5/8	8600	A24R	3890-475	\$1.90	C24R	3890-477	\$2.02	A36T	3893-700	\$4.39	-	-	-
7 x 1/8 x 5/8	8600	-	-	-	-	-	-	-	-	-	C30U	3893-710	\$4.68
8 x 3/32 x 5/8	7500	-	-	-	-	-	-	A36T	3893-705	4.93	-	-	-
8 x 1/8 x 5/8	7500	-	-	-	-	-	-	-	-	-	C30U	3893-715	5.31

CGW – Std. Ctns. of 25

Flexovit USA – Std. Ctns. of 25

Chopsaw/Mitre Saw Wheels

Fiberglass Reinforced – Resin Bonded

Used on lower horsepower bench top chopsaws and mitre saws, these wheels combine optimum cutting speed and wheel life.



SIZE DIA. x THICK. x ARBOR	MAX. RPM	CGW				FLEXOVIT USA			
		GRADE	STD. CTN.	ORDER NO.	PRICE EACH	GRADE	STD. CTN.	ORDER NO.	PRICE EACH
12 x 3/32 x 1	5100	A36P	10	3890-510	\$4.83	A30R	10	3893-730	\$6.39
14 x 3/32 x 1	4400	A36P	10	3890-515	4.81	A30R	10	3893-735	8.57

Masonry Saw Wheels

Fiberglass Reinforced – Resin Bonded

A long life wheel for common brick, light aggregate cement block and fireclay.



SIZE DIA. x THICK. x ARBOR	MAX. RPM	CGW				FLEXOVIT USA			
		GRADE	STD. CTN.	ORDER NO.	PRICE EACH	GRADE	STD. CTN.	ORDER NO.	PRICE EACH
14 x 1/8 x 1	4365	C24R	10	3890-518	\$7.11	C24S	10	3893-740†	\$11.97

† Limited Quantities

High Speed Gas & Electric Saw Wheels

Fiberglass Reinforced – Resin Bonded

Durable, hard working wheels for a variety of job site applications.



SIZE DIA. x THICK. x ARBOR	MAX. RPM	CGW			CGW			FLEXOVIT USA			FLEXOVIT USA		
		METAL, STAINLESS			MASONRY, CONCRETE			METAL, STAINLESS			MASONRY, CONCRETE		
		GRADE	ORDER NO.	PRICE EACH	GRADE	ORDER NO.	PRICE EACH	GRADE	ORDER NO.	PRICE EACH	GRADE	ORDER NO.	PRICE EACH
12 x 1/8 x 1	6300	-	-	-	-	-	-	A24/30S	3893-800	\$6.46	C30U	3893-820	\$6.46
12 x 1/8 x 20MM	6300	-	-	-	-	-	-	A24/30S	3893-805	6.46	C30U	3893-825	6.46
12 x 5/32 x 1	6300	A24R	3890-520	\$5.13	C24R	3890-530	\$5.30	-	-	-	-	-	
12 x 5/32 x 20MM	6300	A24R	3890-522	5.13	C24R	3890-532	5.30	-	-	-	-	-	
14 x 1/8 x 1	5200	-	-	-	-	-	-	A24/30S	3893-810	11.54	C30U	3893-830	11.54
14 x 1/8 x 20MM	5200	-	-	-	-	-	-	A24/30S	3893-815	11.54	C30U	3893-840	11.54
14 x 5/32 x 1	5200	A24R	3890-524	8.74	C24R	3890-534	7.83	-	-	-	-	-	
14 x 5/32 x 20MM	5200	A24R	3890-526	8.74	C24R	3890-536	7.83	-	-	-	-	-	

CGW – Std. Ctns. of 10

Flexovit USA – Std. Ctns. of 10

Type 1 Stationary Saw Wheels

Fiberglass Reinforced – Resin Bonded

For use in production cut-off applications. Fast cutting, reliable performance.

SIZE DIA. x THICK. x ARBOR	MAX. RPM	CGW				FLEXOVIT USA			
		GRADE	STD. CTN.	ORDER NO.	PRICE EACH	GRADE	STD. CTN.	ORDER NO.	PRICE EACH
10 x 1/16 x 5/8	6130	A24R	10	3890-480	\$4.98	-	-	-	-
10 x 3/32 x 5/8	6130	A24R	10	3890-485	4.83	-	-	-	-
10 x 1/8 x 5/8	6130	A24R	10	3890-487	5.00	A30R	10	3893-750	\$8.42
10 x 1/8 x 1	6130	A24R	10	3890-488	5.00	A30R	10	3893-755	8.42
12 x 1/8 x 1	5100	A24R	10	3890-490	5.31	A30R	10	3893-760	10.73
14 x 1/8 x 1	4300	A24R	10	3890-495	4.58	A30R	10	3893-765	15.26
16 x 5/32 x 1	3820	A24R	10	3890-500	13.22	A30R	10	3893-770	21.64
20 x 5/32 x 1	3050	A24R	10	3890-505	18.19	-	-	-	-
20 x 3/16 x 1	3066	-	-	-	-	A30R	10	3893-775	39.04



Turbo

- Turbo rim • Advanced high density bond • High diamond content
- High strength center • Wet or dry cutting
- Clean & smooth, cool & fast cutting; long life
- Use with natural/artificial stone, especially granite
- Masonry products: brick, block
- Concrete, ceramic tile



SIZE	ID/BUSHING	MAX RPM	ORDER NO.	PRICE EACH
4"x.080"x7mm	7/8"-20mm-5/8"B	13,700	5720-138	\$10.80
4-1/2"x.080"x5mm	7/8"-20mm-5/8"B	13,300	5720-140	12.10
5"x.080"x7mm	7/8"-20mm-5/8"B	12,200	5720-142	15.00
7"x.120"x8mm	DIA-7/8"-5/8"B	8,500	5720-144	31.00
7"x.110"x7mm	DIA-7/8"-5/8"B	8,500	5720-146	36.40

Continuous Rim Tile

- Advanced high density bond • High strength center
- High diamond concentration • Chip-free cutting
- Flat, smooth cutting; long life • 4": wet/dry cutting, 8-10": wet
- Use for tile, masonry, stone, granite, marble



SIZE	ID/BUSHING	MAX RPM	ORDER NO.	PRICE EACH
4"x.060"x5mm	7/8"-20mm-5/8"B	13,700	5720-130	\$7.00
8"x.095"x5mm	5/8"	6,800	5720-132	32.20
10"x.110"x7mm	5/8"	6,100	5720-134	39.30

Segmented

- Advanced high density bond • High Diamond content • High strength center
- Segmented rim • High efficiency, fast cutting, long life • Wet or dry cutting
- Masonry products: brick, block
- Concrete, granite, marble



SIZE	ID/BUSHING	MAX RPM	ORDER NO.	PRICE EACH
4"x.070"x7mm	7/8"-20mm-5/8"B	13,700	5720-160	\$11.70
4-1/2"x.080"x7mm	7/8"-20mm-5/8"B	13,300	5720-162	12.10
7"x.090"x7mm	DIA-7/8"-5/8"B	8,500	5720-164	36.40
12"x.120"x10mm	1"-20mmB w/DPH	6,300	5720-166	109.40
14"x.130"x10mm	1"-20mmB w/DPH	5,400	5720-168	130.80

Segmented Turbo

- Segmented turbo-type rim • Advanced high density bond • High Diamond content
- High strength center • Fast cutting, high efficiency, long life
- Wet or dry cutting • Masonry products: brick, block • Marble, concrete



SIZE	ID/BUSHING	MAX RPM	ORDER NO.	PRICE EACH
4"x.085"x7mm	7/8"-20mm-5/8"B	13,700	5720-150	\$13.50
4-1/2"x.090"x7mm	7/8"-20mm-5/8"B	13,300	5720-152	15.50
5"x.100"x7mm	7/8"-20mm-5/8"B	12,200	5720-154	19.00
7"x.110"x7mm	DIA-7/8"-5/8"B	8,500	5720-156	31.30

Segmented Laser

- Laser-welded segments • High density metal bond
- High diamond content • High strength center
- Fast, smooth cutting • Wet or dry cutting
- High efficiency, long life
- Use with walk-behind saws, hard or green concrete, and masonry products

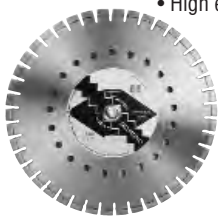

MAX SIZE	ID/BUSHING	RPM	ORDER NO.	PRICE EACH
7"x.085"x7mm	DIA-7/8"-5/8"B	8,500	5720-170	\$55.90
12"x.120"x7mm	1"-20mmB w/DPH	6,300	5720-172	126.40
14"x.125"x7mm	1"-20mmB w/DPH	5,400	5720-174	155.00
14"x.125"x10mm	1"-20mmB w/DPH	5,400	5720-176	253.40

Combo Segmented Laser Segmented Tuck Point

- Laser-welded segments • High density metal bond
- High diamond content • High strength center
- Carbide inserts behind diamond segment
- Fast cutting, high efficiency
- Wet cutting, long life
- Use for walk-behind saws, green concrete, asphalt



SIZE	ID/BUSHING	MAX RPM	ORDER NO.	PRICE EACH
12"x 10mm	1"-20mmB w/DPH	6,300	5720-180	\$171.60
14"x 10mm	1"-20mmB w/DPH	5,400	5720-182	259.00

- Wide welded segments • High strength center
- Effective in repairing or removing grout and mortar joints
- For small circular saws and small right-angle grinders
- High efficiency, good flexibility
- Excellent finishing properties

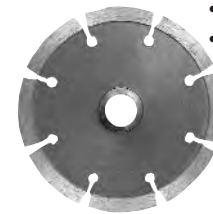

SIZE	ID/BUSHING	MAX RPM	ORDER NO.	PRICE EACH
4"x.250"x8mm	7/8"-5/8"B	14,600	5720-186	\$41.40
7"x.250"x8mm	7/8"-5/8"B	8,500	5720-188	73.30



Type 27 General Purpose Wheels – Aluminum Oxide

Fiberglass Reinforced – Resin Bonded For Metal, Stainless

For safe and efficient metal removal in all portable grinding operations. Remove weld beads, burrs, and rough edges aggressively, yet economically. Long life.



							FLEXOVIT USA			
			ALUMINUM OXIDE				ALUMINUM OXIDE			
SIZE DIA. x THICK. x ARBOR	MAX. RPM	GRADE	STD. CTN.	ORDER NO.	PRICE EACH	GRADE	STD. CTN.	ORDER NO.	PRICE EACH	
4 x 1/4 x 5/8	15000	A24R	25	3890-035	\$1.11	A30S	25	3890-635	\$2.81	
4-1/2 x 1/8 x 7/8	13300	A24R	25	3890-040	1.01	A30S	25	3890-640	2.20	
4-1/2 x 1/4 x 7/8	13300	A24R	25	3890-045	1.26	A30S	25	3890-645	2.32	
4-1/2 x 1/4 x 5/8-11	13300	A24R	10	3890-050	2.59	A30S	10	3890-650	3.83	
5 x 1/4 x 7/8	12000	A24R	25	3890-060	1.55	A30S	25	3890-660	3.80	
7 x 1/8 x 7/8	8600	A24R	25	3890-063	2.08	A30S	25	3890-663	4.61	
7 x 1/8 x 5/8-11	8600	A24R	10	3890-065	3.69	A30S	10	3890-665	6.34	
7 x 1/4 x 7/8	8600	A24R	25	3890-070	2.30	A30S	25	3890-670	4.72	
7 x 1/4 x 5/8-11	8600	A24R	10	3890-075	4.04	A30S	10	3890-675	6.46	
9 x 1/8 x 7/8	6800	A24R	25	3890-083	2.61	A30S	25	3890-683	6.41	
9 x 1/8 x 5/8-11	6800	A24R	10	3890-085	4.35	A30S	10	3890-685	8.14	
9 x 1/4 x 7/8	6800	A24R	25	3890-090	3.65	A30S	25	3890-690	6.62	
9 x 1/4 x 5/8-11	6800	A24R	10	3890-095	5.41	A30S	10	3890-695	8.37	

Type 27 Premium Performance – Zirconia Aluminum

Fiberglass Reinforced – Resin Bonded For Metal, Stainless Alloys

							FLEXOVIT USA			
			ZIRCONIA ALUMINUM				ZIRCONIA ALUMINUM			
SIZE DIA. x THICK. x ARBOR	MAX. RPM	GRADE	STD. CTN.	ORDER NO.	PRICE EACH	GRADE	STD. CTN.	ORDER NO.	PRICE EACH	
4 x 1/4 x 5/8	15000	ZA24T	25	3890-835†	\$ 2.39	–	–	–	–	
4-1/2 x 1/8 x 7/8	13300	ZA24T	25	3890-840	2.26	ZA24S	10	3890-940†	\$ 7.43	
4-1/2 x 1/4 x 7/8	13300	ZA24T	25	3890-845	2.89	ZA20Q	10	3890-945	8.91	
4-1/2 x 1/4 x 5/8-11	13300	ZA24T	10	3890-850	4.39	–	–	–	–	
7 x 1/8 x 5/8-11	8600	–	–	–	–	ZA24S	10	3890-973	10.91	
7 x 1/4 x 7/8	8600	ZA24T	25	3890-874	4.96	ZA20Q	10	3890-974	12.26	
7 x 1/4 x 5/8-11	8600	ZA24T	10	3890-875	6.89	ZA20Q	10	3890-975	13.99	
9 x 1/8 x 7/8	6800	–	–	–	–	ZA24S	10	3890-990	13.10	
9 x 1/8 x 5/8-11	6800	–	–	–	–	ZA24S	10	3890-993	14.85	
9 x 1/4 x 7/8	6800	ZA24T	25	3890-894	8.17	ZA20Q	10	3890-994	16.27	
9 x 1/4 x 5/8-11	6800	ZA24T	10	3890-895	10.09	ZA20Q	10	3890-995	18.02	

† Limited Quantities

Depressed Center Wheels

1

Buy
Std. Ctn.
Deduct
10%



Type 27 Quickie Cut™ Thin Reinforced Cut-Off Wheels

CGW Quickie Cut™ Thin Reinforced Type 27 Cut-Off wheels are an excellent general purpose wheel with an Aluminum Oxide / Zirconia mixture. Zirconia grain allows for faster cutting and longer life. Use on Steel and Stainless Steel.

		CGW USA			
SIZE DIA. x THICK. x ARBOR	SPEC	MAX. RPM	STD. CTN.	ORDER NO.	PRICE EACH
4 x .040 x 5/8	ZA60-S-BF	15,300	25	3898-705	\$1.22
4 1/2 x .045 x 7/8	ZA60-S-BF	13,300	25	3898-710	1.22
5 x .045 x 7/8	ZA60-S-BF	12,250	25	3898-715	1.39
6 x .045 x 7/8	ZA60-S-BF	10,200	25	3898-720	1.72
7 x 1/16 x 7/8	ZA60-S-BF	8,500	25	3898-725	2.39
9 x 1/16 x 7/8	ZA60-S-BF	6,600	25	3898-730	3.13



Type 27 For Masonry, Concrete

Silicon Carbide Depressed Center Wheels

Made with silicon carbide grain, C24R is designed for all concrete and masonry applications. Also offers fast grinding action on nonferrous materials.

		CGW USA			
SIZE DIA. x THICK. x ARBOR	MAX. RPM	GRADE	STD. CTN.	ORDER NO.	PRICE EACH
4-1/2 x 1/4 x 7/8	13300	C24R	25	3898-780	\$2.56
7 x 1/4 x 5/8-11	8600	C24R	10	3898-785	6.39
9 x 1/4 x 5/8-11	6600	C24R	10	3898-790	8.69

Type 28 General Purpose Wheels

Fiberglass Reinforced – Resin Bonded For Metal, Stainless

Type 28 ("saucer shaped") wheels will grind aggressively at less than a 15 Degree angle to the workpiece, versus 30 to 45 Degrees for a Type 27 wheel. This brings the operators elbow down to a more comfortable level in some applications, reducing fatigue.



		CGW USA				FLEXOVIT USA			
SIZE DIA. x THICK. x ARBOR	MAX. RPM	GRADE	STD. CTN.	ORDER NO.	PRICE EACH	GRADE	STD. CTN.	ORDER NO.	PRICE EACH
4-1/2 x 1/4 x 7/8	12000	-	-	-	-	A30S	25	3890-740	\$3.64
7 x 1/4 x 7/8	8600	A24R	25	3890-170	\$3.04	A30S	25	3890-770	6.17
7 x 1/4 x 5/8-11	8600	A24R	10	3890-175	4.80	A30S	10	3890-775	7.92
9 x 1/4 x 7/8	6800	A24R	25	3890-190	4.93	A30S	25	3890-790	8.95
9 x 1/4 x 5/8-11	6800	A24R	10	3890-195	6.67	A30S	10	3890-795	10.69



Type 27 Cut/Grind/Finish Reinforced Rt. Angle Grinder Wheels

High performance wheels made to cut quickly, grind easily and finish work surfaces with ONE wheel. Fiberglass net reinforcement provides added strength and flexibility. For working on flat grinding surfaces. Most efficient when used between 0° - 15° angle. The best choice for smooth finishing. Suitable For: Steel & Stainless Steel. Contaminate free wheel has < 0.1% iron, sulfur, or chlorine for rust-free and corrosion-free results.

		CGW USA			
SIZE DIA. x THICK. x ARBOR	SPEC	MAX. RPM	STD. CTN.	ORDER NO.	PRICE EACH
4 1/2 x 3/32 x 7/8	A36S	13,300	25	3898-755	\$2.07
4 1/2 x 3/32 x 5/8-11	A36S	13,300	10	3898-756	3.67
5 x 3/32 x 7/8	A36S	12,250	25	3898-760	2.46
5 x 3/32 x 5/8-11	A36S	12,250	10	3898-761	4.06
6 x 3/32 x 7/8	A36S	10,200	25	3898-765	3.31
6 x 3/32 x 5/8-11	A36S	10,200	10	3898-766	4.89

Type 27 & Type 29 Semi-Flexible Wheels

Eliminate wheel-change downtime by grinding and finishing with the same wheel. A high quality aluminum grinding product, runs virtually "load free". Performs well in all metal applications. Available in convex faced Type 29 for contoured surfaces, or Type 27 for flat surfaces. Use at a minimum 15 Degree angle. Do not use flat.

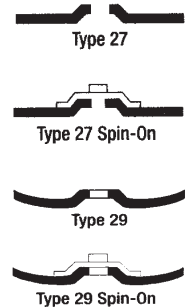

		FLEXOVIT USA			
SIZE DIA. x THICK. x ARBOR	MAX. RPM	FINISH	STD. CTN.	ORDER NO.	PRICE EACH
		Type 27 Medium			
4-1/2 x 1/8 x 7/8	13300	24-60 Grit	25	3893-504	\$5.78
7 x 1/8 x 5/8-11	8600	24-60 Grit	25	3893-517	10.40
		Type 29 Medium			
7 x 1/8 x 5/8-11	8600	24-60 Grit	25	3893-547	10.40

Abrasive Flap Discs

1

Buy
Std. Ctn.
Deduct
10%

Zirconium Abrasive Flap Discs are used for coarse and intermediate grinding of welds, deburring, rust removal and snagging. Bridges the gap between angle grinding wheels and resin fiber discs, providing aggressive cutting action and longer life than fiber discs.

Type 29 – Angled Style Flap Discs – Zirconium Grain

A working angle of 15 to 25 Degrees. Excellent for contour or edge work.

- Phenolic resin/fiber backing is used to prevent scratching the work piece during operation.
- Aluminum backing provides rigid support for maximum aggression; recyclable.
- CGW XL discs have approximately 60% more material.

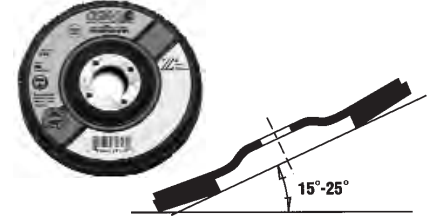

				VORTEC		CGW USA MADE		CGW XL USA MADE		Weiler TIGER			
				PHENOLIC BACKING		PHENOLIC BACKING		PHENOLIC BACKING		PHENOLIC BACKING		ALUMINUM BACKING	
SIZE	GRIT	STD. CTN.	ORDER NO.	PRICE	ORDER NO.	PRICE	ORDER NO.	PRICE	ORDER NO.	PRICE	ORDER NO.	PRICE	
4-1/2 x 7/8	24	10	6531-342	\$3.20	5720-422	\$3.70	-	-	6550-601	\$5.98	6550-511	\$7.00	
4-1/2 x 7/8	36	10	6531-343	3.20	5720-423	3.70	5720-823	\$4.65	6550-602	5.98	6550-512	7.00	
4-1/2 x 7/8	40	10	6531-344	3.20	5720-424	3.70	5720-824	4.65	6550-603	5.98	6550-513	7.00	
4-1/2 x 7/8	60	10	6531-345	3.20	5720-426	3.70	5720-826	4.65	6550-604	5.98	6550-514	7.00	
4-1/2 x 7/8	80	10	6531-346	3.20	5720-428	3.70	5720-828	4.65	6550-605	5.98	6550-515	7.00	
4-1/2 x 7/8	120	10	6531-347	3.20	5720-432	3.70	5720-832	4.65	6550-606	5.98	6550-516	7.00	
7 x 7/8	40	10	-	-	5720-484	7.24	-	-	-	-	6550-533	14.00	
7 x 7/8	60	10	-	-	5720-486	7.24	-	-	-	-	6550-534	14.00	
7 x 7/8	80	10	-	-	5720-488	7.24	-	-	-	-	6550-535	14.00	

Other sizes, and 5/8-11 Hub Style are also available. Std. Carton Qty. only.

Type 27 – Flat Style Flap Discs

Ideal for working angles less than 15 Degrees. Smooth grinding. Zirconium Grain

High rate of stock removal and long life in demanding applications.

CGW XL and Weiler Big Cat® Abrasive Flap Discs feature a thicker disc with a higher density of flaps which conform to curved surfaces producing a consistent finish. 30% to 40% longer life than standard flap discs. For those who value parts-per-disc over price-per-disc.

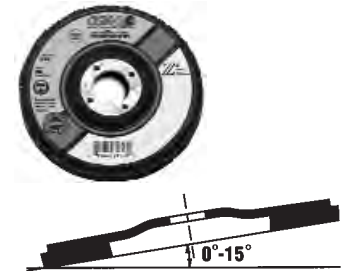

				CGW USA MADE		Weiler TIGER		CGW XL USA MADE		Weiler TIGER Big Cat®	
				PHENOLIC BACKING ZIRCONIUM GRAIN		PHENOLIC BACKING ZIRCONIUM GRAIN		PHENOLIC BACKING ZIRCONIUM GRAIN		PHENOLIC BACKING ZIRCONIUM GRAIN	
SIZE	GRIT	STD. CTN.	ORDER NO.	PRICE	ORDER NO.	PRICE	ORDER NO.	PRICE	ORDER NO.	PRICE	
4-1/2 x 7/8	24	10	5720-222	\$3.70	-	-	-	-	-	-	
4-1/2 x 7/8	36	10	5720-223	3.70	-	-	5720-623	\$4.65	-	-	
4-1/2 x 7/8	40	10	5720-224	3.70	6550-703	\$5.98	5720-624	4.65	6550-803	\$ 7.44	
4-1/2 x 7/8	60	10	5720-226	3.70	6550-704	5.98	5720-626	4.65	6550-804	7.44	
4-1/2 x 7/8	80	10	5720-228	3.70	6550-705	5.98	5720-628	4.65	6550-805	7.44	
4-1/2 x 7/8	120	10	5720-232	3.70	6550-706	5.98	5720-632	4.65	6550-806	7.44	
7 x 7/8	40	10	5720-284	7.24	-	-	-	-	-	-	
7 x 7/8	60	10	5720-286	7.24	-	-	-	-	-	-	
7 x 7/8	80	10	5720-288	7.24	-	-	-	-	-	-	

Adapting Nuts & Spanner Wrench – For discs with 7/8" arbor hole

DESCRIPTION	THREAD	ORDER NO.	PRICE EACH
Adapting nuts	5/8-11	6556-494	\$21.02
Spanner wrench	-	6556-495	16.91

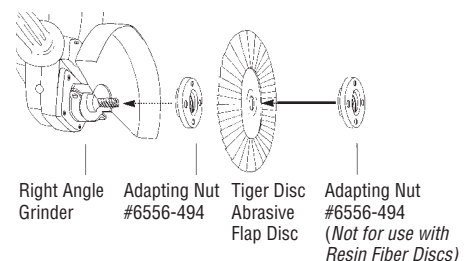
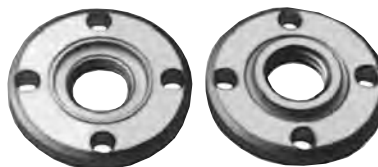

Mini Flap Discs & Quick Change Discs

1

Buy
Std. Ctn.
Deduct
10%

Mini Flap Discs - Type 27

Zirconia Grain



For use on Die Grinders, these mini flap discs combine grinding and finishing applications into one step, while providing the convenience and versatility of Quick Change Discs. They are designed to prevent walking, allow access to tight areas, and reduce heat build-up.

Applications:

- Grinding and finishing in one step.
- Grinding, deburring and blending on steel/stainless steel.
- Jobs requiring high aggression & rapid stock removal.
- Metal fabrication requiring light weld blending or edge chamfering.

				CGW USA MADE		TIGER BOBCat®			
				TYPE 27 (S HUB)		TYPE 27 (R HUB)		TYPE 27 (S HUB)	
SIZE	GRIT	RPM	PKG. QTY.	ORDER NO.	PRICE	ORDER NO.	PRICE	ORDER NO.	PRICE
2"	36	24,000	10	5722-003	\$24.41	5722-023	\$24.41	6550-932	\$38.99
2"	40	24,000	10	5722-004	24.41	5722-024	24.41	6550-933	38.99
2"	60	24,000	10	5722-006	24.41	5722-026	24.41	6550-934	38.99
2"	80	24,000	10	5722-008	24.41	5722-028	24.41	6550-935	38.99
2"	120	24,000	10	5722-010	24.41	5722-030	24.41	6550-936	38.99
3"	36	20,000	10	5722-013	36.72	5722-033	36.72	6550-912	50.30
3"	40	20,000	10	5722-014	36.72	5722-034	36.72	6550-913	50.30
3"	60	20,000	10	5722-016	32.62	5722-036	32.62	6550-914	50.30
3"	80	20,000	10	5722-018	32.62	5722-038	32.62	6550-915	50.30
3"	120	20,000	10	5722-020	32.62	5722-040	32.62	6550-916	50.30

CGW Quick Change Laminated Discs

Use on Die Grinders for deburring, blending, finishing, removing tool marks, and die polishing on all types of materials. Suitable for a wide variety of light fabrication, repair and maintenance applications. Strong 2-Ply design for flat or contour work.

Aluminum Oxide - Color: Brown General purpose disc for grinding, deburring, and blending on ferrous metals.

Zirconia AO w/Grinding Aid - COLOR: GREEN Excellent disc for rapid stock removal on Stainless Steel. Lubricated super-size Grinding Aid coat for cooler running.

Premium Ceramic - Color: Pink Premium grain for greater durability and aggressive cut rates, including hard metals.

Turn On style,
(S-Hub) shown



				CGW USA MADE								
				ALUMINUM OXIDE			ZIRCONIA AO W/GRINDING AID			PREMIUM CERAMIC		
DIAM.	GRIT	RPM	PKG. QTY.	ROLL ON (R HUB) ORDER NO.	TURN ON (S HUB) ORDER NO.	PRICE PER PACK	ROLL ON (R HUB) ORDER NO.	TURN ON (S HUB) ORDER NO.	PRICE PER PACK	ROLL ON (R HUB) ORDER NO.	TURN ON (S HUB) ORDER NO.	PRICE PER PACK
2"	36	25,000	50	5722-223	5722-623	\$22.56	5722-323	5722-723	\$31.79	5722-523	5722-923	\$35.90
	40	25,000	50	5722-224	5722-624	20.51	5722-324	5722-724	28.72	5722-524	5722-924	33.85
	50	25,000	50	5722-225	5722-625	20.51	5722-325	5722-725	28.72	5722-525	5722-925	31.79
	60	25,000	50	5722-226	5722-626	20.51	5722-326	5722-726	28.72	5722-526	5722-926	28.72
	80	25,000	50	5722-228	5722-628	19.49	5722-328	5722-728	28.72	5722-528	5722-928	27.69
	100	25,000	50	5722-230	5722-630	19.49	-	-	-	5722-530	5722-930	27.69
	120	25,000	50	5722-232	5722-632	19.49	5722-332	5722-732	28.72	5722-532	5722-932	27.69
3"	36	20,000	25	5722-243	5722-643	17.95	5722-343	5722-743	23.59	5722-543	5722-943	33.33
	40	20,000	25	5722-244	5722-644	16.41	5722-344	5722-744	20.00	5722-544	5722-944	31.28
	50	20,000	25	5722-245	5722-645	16.41	5722-345	5722-745	20.00	5722-545	5722-945	29.23
	60	20,000	25	5722-246	5722-646	16.41	5722-346	5722-746	20.00	5722-546	5722-946	25.64
	80	20,000	25	5722-248	5722-648	14.87	5722-348	5722-748	20.00	5722-548	5722-948	24.10
	100	20,000	25	5722-250	5722-650	14.87	-	-	-	5722-550	5722-950	23.08
	120	20,000	25	5722-252	5722-652	14.87	5722-352	5722-752	20.00	5722-552	5722-952	23.08

Quick Change Disc Rubber Holder Pads

- Medium grade reinforced rubber holder pad.
- Available for either internally threaded (S Hub) or externally threaded (R Hub) Quick Change discs.



SIZE	RPM	R-HUB		S-HUB	
		ORDER NO.	PRICE EACH	ORDER NO.	PRICE EACH
1"	40,000	5723-400	\$4.82	5723-410	\$5.49
1-1/2"	25,000	5723-401	5.39	5723-411	5.98
2"	25,000	5723-402	5.98	5723-412	6.29
3"	20,000	5723-403	6.63	5723-413	7.09

Resin Fibre Discs

1

Buy
Std. Ctn.
Deduct
10%

GRAIN SELECTOR		
GRAIN	FEATURES	APPLICATIONS
Aluminum Oxide	<ul style="list-style-type: none"> Fast, smooth cutting action Tough and flexible High resistance to heat, glazing, and loading 	<ul style="list-style-type: none"> All purpose weld removal and blending Surface preparation and finishing of ferrous metals, plastic, and wood
Zirconium	<ul style="list-style-type: none"> Superior cutting action More durable – longer life Ultra high resistance to heat, glazing, and loading 	<ul style="list-style-type: none"> High performance grinding of stainless steel, tool steel, and hard-to-grind materials and exotic metals.



						CGW		Weiler TIGER		SA STANDARD ABRASIVES	
				ALUMINUM OXIDE		ZIRCONIUM		ALUMINUM OXIDE		ALUMINUM OXIDE	
SIZE	GRIT	STD. CTN.	ORDER NO.	PRICE	ORDER NO.	PRICE	ORDER NO.	PRICE	ORDER NO.	PRICE	
4 x 5/8	24	25	5710-152	\$0.50	-	-	-	-	-	-	
4 x 5/8	36	25	5710-153	0.46	-	-	-	-	-	-	
4 x 5/8	50	25	5710-155	0.44	-	-	-	-	-	-	
4 x 5/8	60	25	5710-156	0.44	-	-	-	-	-	-	
4 x 5/8	80	25	5710-158	0.42	-	-	-	-	-	-	
4-1/2 x 7/8	16	25	5710-201	0.61	-	-	-	-	-	-	
4-1/2 x 7/8	24	25	5710-202	0.54	5710-432	\$0.75	6559-571	\$0.94	5616-132	\$1.21	
4-1/2 x 7/8	36	25	5710-203	0.48	5710-433	0.71	6559-573	0.86	5616-133	1.17	
4-1/2 x 7/8	50	25	5710-205	0.48	5710-435	0.69	6559-575	0.82	5616-135	1.12	
4-1/2 x 7/8	60	25	5710-206	0.44	5710-436	0.65	6559-576	0.80	5616-136	1.04	
4-1/2 x 7/8	80	25	5710-208	0.42	5710-438	0.60	6559-577	0.73	5616-138	0.99	
4-1/2 x 7/8	100	25	5710-210	0.42	-	-	-	-	-	-	
4-1/2 x 7/8	120	25	5710-212	0.42	-	-	-	-	-	-	
5 x 7/8	16	25	5710-251	0.82	-	-	-	-	-	-	
5 x 7/8	24	25	5710-252	0.56	5710-462	0.85	6559-501	1.04	5616-162	1.27	
5 x 7/8	36	25	5710-253	0.54	5710-463	0.77	6559-503	1.01	5616-163	1.21	
5 x 7/8	50	25	5710-255	0.52	5710-465	0.73	6559-505	0.97	5616-165	1.17	
5 x 7/8	60	25	5710-256	0.48	5710-466	0.71	6559-506	0.86	5616-166	1.10	
5 x 7/8	80	25	5710-258	0.46	5710-468	0.67	6559-507	0.84	5616-168	1.03	
5 x 7/8	100	25	5710-260	0.46	-	-	6559-508	0.84	-	-	
5 x 7/8	120	25	5710-262	0.46	-	-	6559-509	0.84	-	-	
7 x 7/8	16	25	5710-301	1.00	-	-	6559-520	1.91	-	-	
7 x 7/8	24	25	5710-302	0.88	-	-	6559-521	1.71	5616-202	1.96	
7 x 7/8	36	25	5710-303	0.82	-	-	6559-523	1.64	5616-203	1.90	
7 x 7/8	50	25	5710-305	0.79	5710-505	1.21	6559-525	1.54	5616-205	1.84	
7 x 7/8	60	25	5710-306	0.79	5710-506	1.11	6559-526	1.54	5616-206	1.70	
7 x 7/8	80	25	5710-308	0.73	5710-508	1.05	6559-527	1.41	5616-208	1.60	
7 x 7/8	100	25	5710-310	0.73	-	-	6559-528	1.41	-	-	
7 x 7/8	120	25	5710-312	0.73	-	-	6559-529	1.41	-	-	

Spiralcool Standard Air-Cooled Backing Pads

Ideal for all sanding operations on metal, plastic, fiberglass, etc. Smooth face pads available upon request.

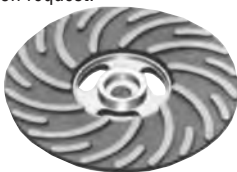

Supplied with 5/8-11 Arbor Hole, except the 4-1/2" which will be supplied with a 5/8" smooth bore. Other arbor holes available upon request.

SIZE	DENSITY	MAX. RPM	ORDER NO.	PRICE EACH
4"	Flexible	12,000	5710-600	\$11.50
4"	Medium	12,000	5710-601	11.50
4"	Rigid	12,000	5710-602	11.50
4-1/2"	Flexible	11,000	5710-612	11.50
4-1/2"	Medium	11,000	5710-613	11.50
4-1/2"	Rigid	11,000	5710-614	11.50
5"	Flexible	10,000	5710-624	13.05
5"	Medium	10,000	5710-625	13.05
5"	Rigid	10,000	5710-626	13.05
7"	Flexible	7,000	5710-636	19.60
7"	Medium	8,500	5710-637	19.60
7"	Rigid	8,500	5710-638	19.60
9"	Flexible	6,500	5710-648	23.45
9"	Medium	6,500	5710-649	23.45
9"	Rigid	6,500	5710-650	23.45

1



Nuts and wrenches do not come with pads. Must be ordered separately.

DESCRIPTION	ORDER NO.	PRICE EACH
#102 Nut; 5/8-11	5710-665	\$4.55
#103 Nut; 5/8-11 For 4" - 5" Pads	5710-666	4.55
3/8-24 - 5/8-11 Adapter	5710-660	7.25
7/16-20 - 5/8-11 Adapter	5710-661	7.25
Spanner Wrench	5710-670	4.55

PSA Discs

PSA Aluminum Oxide Resin Bond Cloth Discs

Abrasive cloth discs have a pressure sensitive adhesive backing making them easy to apply to a rubber disc holder. Protective liner speeds disc changing and protects adhesive from work dust. Resin bond discs are made with a heavy resin abrasive cloth, assuring long life, with fast stock removal.

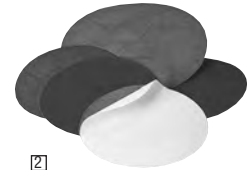

IMPORT				STANDARD ABRASIVES		
GRIT	ORDER NO.	PKG QTY	PRICE PER PKG	ORDER NO.	PKG QTY	PRICE PER PKG
1/2" DIAMETER						
60	-	-	-	5620-006	100	\$8.15
80	-	-	-	5620-008	100	8.15
100	-	-	-	5620-010	100	8.15
120	-	-	-	5620-012	100	8.15
180	-	-	-	5620-018	100	8.15
240	-	-	-	5620-024	100	8.15
320	-	-	-	5620-032	100	8.15
3/4" DIAMETER						
40	-	-	-	5620-054	100	\$9.78
50	-	-	-	5620-055	100	9.78
60	-	-	-	5620-056	100	9.78
80	-	-	-	5620-058	100	9.78
100	-	-	-	5620-060	100	9.78
120	-	-	-	5620-062	100	9.78
180	-	-	-	5620-068	100	9.78
240	-	-	-	5620-074	100	9.78
320	-	-	-	5620-082	100	9.78
1" DIAMETER						
36	5711-103	100	\$11.35	-	-	-
40	5711-104	100	10.20	5620-104	100	\$17.93
50	5711-105	100	10.20	5620-105	100	17.93
60	5711-106	100	10.20	5620-106	100	17.93
80	5711-108	100	10.20	5620-108	100	17.93
100	5711-110	100	10.20	5620-110	100	17.93
120	5711-120	100	10.20	5620-112	100	17.93
180	-	-	-	5620-118	100	17.93
240	-	-	-	5620-124	100	17.93
320	-	-	-	5620-132	100	17.93
1-1/2" DIAMETER						
36	5711-153	100	\$14.50	5620-153	100	\$24.45
40	5711-154	100	13.90	-	-	-
50	5711-155	100	13.20	5620-155	100	22.82
60	5711-156	100	13.20	5620-156	100	22.01
80	5711-158	100	13.20	5620-158	100	22.01
100	5711-160	100	13.20	5620-160	100	22.01
120	5711-162	100	13.20	5620-162	100	22.01
180	-	-	-	5620-168	100	22.01
240	-	-	-	5620-174	100	22.01
320	-	-	-	5620-182	100	22.01
2" DIAMETER						
36	5711-203	100	\$26.90	-	-	-
40	5711-204	100	25.60	5620-204	100	\$44.01
50	5711-205	100	24.40	5620-205	100	42.38
60	5711-206	100	23.20	5620-206	100	39.94
80	5711-208	100	22.15	5620-208	100	38.31
100	5711-210	100	21.05	5620-210	100	37.49
120	5711-212	100	21.05	5620-212	100	36.68
180	-	-	-	5620-218	100	37.49
240	-	-	-	5620-224	100	37.49
320	-	-	-	5620-232	100	37.49

IMPORT				STANDARD ABRASIVES		
GRIT	ORDER NO.	PKG QTY	PRICE PER PKG	ORDER NO.	PKG QTY	PRICE PER PKG
3" DIAMETER						
36	5711-253	100	\$38.65	5620-253	100	\$50.53
40	5711-254	100	36.90	5620-254	100	49.72
50	5711-255	100	34.40	5620-255	100	47.27
60	5711-256	100	30.90	5620-256	100	44.83
80	5711-258	100	30.65	5620-258	100	43.20
100	5711-260	100	29.25	5620-260	100	41.57
120	5711-262	100	29.25	5620-262	100	41.57
180	-	-	-	5620-268	100	42.38
240	-	-	-	5620-274	100	42.38
320	-	-	-	5620-282	100	42.38
4" DIAMETER						
36	-	-	-	5620-303	50	\$33.82
60	-	-	-	5620-306	50	27.71
80	-	-	-	5620-308	50	26.49
100	-	-	-	5620-310	50	25.67
120	-	-	-	5620-312	50	25.67
180	-	-	-	5620-318	50	25.67
240	-	-	-	5620-324	50	25.67
5" DIAMETER						
36	5711-303	50	\$38.90	5620-353	50	\$25.06
40	5711-304	50	36.70	5620-354	50	47.68
50	5711-305	50	34.65	5620-355	50	44.01
60	5711-306	50	32.65	-	-	-
80	5711-308	50	30.80	5620-358	50	39.94
100	5711-310	50	28.85	5620-360	50	38.31
120	5711-312	50	28.80	5620-362	50	38.31
180	-	-	-	5620-368	50	38.31
240	-	-	-	5620-374	50	38.31
320	-	-	-	5620-382	50	38.31
6" DIAMETER						
36	5711-353	50	\$59.30	-	-	-
40	5711-354	50	56.85	5620-404	50	70.91
50	5711-355	50	52.85	5620-405	50	66.83
60	5711-356	50	45.55	5620-406	50	60.31
80	5711-358	50	44.70	5620-408	50	57.87
100	5711-360	50	41.80	5620-410	50	55.83
120	5711-362	50	41.80	5620-412	50	55.83
180	-	-	-	5620-418	50	55.83
240	-	-	-	5620-424	50	55.83
320	-	-	-	5620-432	50	55.83
8" DIAMETER						
24	-	-	-	5620-452	10	\$29.01
36	5711-453	50	\$100.45	5620-453	10	26.41
40	5711-454	50	96.40	5620-454	10	25.10
50	5711-455	50	89.55	5620-455	10	23.96
60	5711-456	50	83.60	5620-456	10	22.74
80	5711-458	50	75.75	5620-458	10	21.68
100	5711-460	50	73.60	5620-460	10	20.70
120	5711-462	50	73.60	5620-462	10	20.70
180	-	-	-	5620-468	10	20.70
240	-	-	-	5620-474	10	20.70

IMPORT				STANDARD ABRASIVES		
GRIT	ORDER NO.	PKG QTY	PRICE PER PKG	ORDER NO.	PKG QTY	PRICE PER PKG
9" DIAMETER						
36	5711-503	50	\$139.15	5620-503	10	\$37.57
40	5711-504	50	133.30	5620-504	10	35.45
50	5711-505	50	120.95	5620-505	10	33.42
60	5711-506	50	109.25	5620-506	10	31.46
80	5711-508	50	104.00	5620-508	10	29.75
100	5711-510	50	98.55	5620-510	10	28.04
120	-	-	-	5620-512	10	28.04
12" DIAMETER						
24	-	-	-	5620-552	10	\$72.78
36	-	-	-	5620-553	10	63.57
40	5711-604	25	\$115.75	5620-554	10	61.13
50	5711-605	25	109.20	5620-555	10	57.78
60	5711-606	25	93.70	5620-556	10	53.38
80	5711-608	25	91.70	5620-558	10	50.37
100	5711-610	25	87.05	5620-560	10	48.57
120	5711-612	25	87.05	5620-562	10	48.57
180	-	-	-	5620-568	10	48.57
240	-	-	-	5620-574	10	48.57
320	-	-	-	5620-582	10	48.57
16" DIAMETER						
36	-	-	-	5620-653	10	\$119.40
40	-	-	-	5620-654	10	112.63
50	-	-	-	5620-655	10	106.28
60	-	-	-	5620-656	10	100.98
80	-	-	-	5620-658	10	94.46
120	-	-	-	5620-662	10	89.24
20" DIAMETER						
24	-	-	-	5620-702	10	\$206.85
36	-	-	-	5620-703	10	180.52
40	-	-	-	5620-704	10	170.99
50	-	-	-	5620-705	10	163.73
60	-	-	-	5620-706	10	151.59
80	-	-	-	5620-708	10	143.03
100	-	-	-	5620-710	10	137.49
120	-	-	-	5620-712	10	137.49
180	-	-	-	5620-718	10	137.49
240	-	-	-	5620-724	10	137.49
24" DIAMETER						
24	-	-	-	5620-752	10	\$ 295.76
36	-	-	-	5620-753	10	261.70
40	-	-	-	5620-754	10	244.66
50	-	-	-	5620-755	10	229.75
60	-	-	-	5620-756	10	216.30
80	-	-	-	5620-758	10	201.31



PSA Abrasive Disc - Disc Rolls With Liner

Silicon Carbide Grain glue bond, "A" weight paper. Treated for load resistance, recommended for all grinding of metal, wood and fiberglass. With release paper liner and self storing dispenser. Trouble free, the most efficient disc/roll package available. No grit or dust contamination, great shelf life. Stearate coated.

GRIT	PKG QTY	5"		6"	
		ORDER NO.	PRICE PER PKG	ORDER NO.	PRICE PER PKG
80	100	5712-308	\$21.30	5712-408	\$25.95
100	100	5712-310	20.35	5712-410	24.80
120	100	5712-312	20.35	5712-412	24.80
150	100	5712-315	20.35	5712-415	24.80
180	100	5712-318	20.35	5712-418	24.80
220	100	5712-322	20.35	5712-422	24.80
320	100	5712-332	20.35	5712-432	24.80

PSA Disc Holders - Optimum performance with PSA Discs



DIAM.	MAX. RPM	SHK	ORDER NO.	PRICE EACH
1/2	18,000	1/4	5642-190	\$ 2.63
3/4	18,000	1/4	5642-191	2.79
1	15,000	1/4	5642-192	3.51
1-1/2	15,000	1/4	5642-193	4.49
2	12,000	1/4	5642-194	5.81
3	10,000	1/4	5642-195	6.40
4	7,000	1/4	5642-196	7.04
5	5,000			

STANDARD ABRASIVES Quick Change Discs

Available in a Choice of Quick Change Locking Systems.

4

A/O 2 Ply Discs

Color: Brown

Best Disc For: General Purpose grinding, deburring, and blending on ferrous metals.

	TS-STYLE	TR-STYLE	TP-STYLE		
GRIT	ORDER NO.	ORDER NO.	ORDER NO.	PKG QTY	PRICE PER PKG
1" DIAMETER					
24	5600-102	-	-	100	\$45.00
36	5600-103	-	-	100	43.20
40	5600-104	-	-	100	42.30
50	5600-105	-	-	100	40.50
60	5600-106	-	-	100	37.80
80	5600-108	-	-	100	36.00
100	5600-110	-	-	100	36.00
120	5600-112	-	-	100	36.00
150	5600-115	-	-	100	36.00
180	5600-118	-	-	100	36.00
240	5600-124	-	-	100	36.00
320	5600-132	-	-	100	36.00
1-1/2" DIAMETER					
24	5600-152	5600-652	-	100	\$52.20
36	5600-153	5600-653	5601-153	100	49.50
40	5600-154	5600-654	5601-154	100	48.60
50	5600-155	5600-655	5601-155	100	48.60
60	5600-156	5600-656	5601-156	100	47.70
80	5600-158	5600-658	5601-158	100	46.80
100	5600-160	5600-660	5601-160	100	46.80
120	5600-162	5600-662	5601-162	100	46.80
150	5600-165	5600-665	5601-165	100	46.80
180	5600-168	5600-668	5601-168	100	46.80
240	5600-174	5600-674	5601-174	100	46.80
320	5600-182	5600-682	5601-182	100	46.80
2" DIAMETER					
24	5600-202	5600-702	-	100	\$81.90
36	5600-203	5600-703	5601-203	100	77.40
40	5600-204	5600-704	5601-204	100	73.80
50	5600-205	5600-705	5601-205	100	72.00
60	5600-206	5600-706	5601-206	100	69.30
80	5600-208	5600-708	5601-208	100	68.40
100	5600-210	5600-710	5601-210	100	67.50
120	5600-212	5600-712	5601-212	100	67.50
150	5600-215	5600-715	5601-215	100	67.50
180	5600-218	5600-718	5601-218	100	67.50
240	5600-224	5600-724	5601-224	100	67.50
320	5600-232	5600-732	5601-232	100	67.50
3" DIAMETER					
24	5600-302	5600-802	-	50	\$51.75
36	5600-303	5600-803	5601-303	50	48.60
40	5600-304	5600-804	5601-304	50	47.25
50	5600-305	5600-805	5601-305	50	45.45
60	5600-306	5600-806	5601-306	50	44.10
80	5600-308	5600-808	5601-308	50	42.75
100	5600-310	5600-810	5601-310	50	41.85
120	5600-312	5600-812	5601-312	50	41.85
150	5600-315	5600-815	5601-315	50	41.85
180	5600-318	5600-818	5601-318	50	47.25
240	5600-324	5600-824	5601-324	50	41.85
320	5600-332	5600-832	5601-332	50	47.25

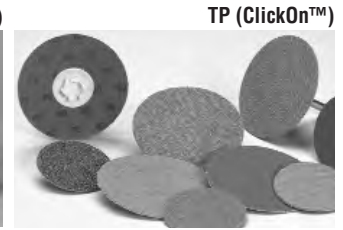
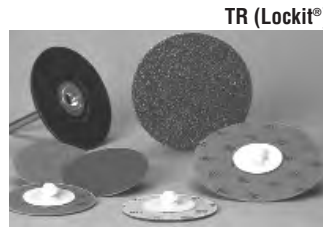

A/O Extra 2 Ply Discs

Color: Light Brown

Best Disc For: Difficult to grind metals such as aircraft grade Aluminum, High Nickel, Chrome Alloys, and heat sensitive metals. Provides lower heat generation than regular Aluminum Oxide on Ferrous metals.

	TS-STYLE	TR-STYLE	TP-STYLE		
GRIT	ORDER NO.	ORDER NO.	ORDER NO.	PKG QTY	PRICE PER PKG
1" DIAMETER					
36	5601-603	-	-	100	\$45.00
50	5601-605	-	-	100	42.30
60	5601-606	-	-	100	41.40
80	5601-608	-	-	100	40.50
100	5601-610	-	-	100	40.50
120	5601-612	-	-	100	40.50
1-1/2" DIAMETER					
36	5601-653	5602-153	-	100	\$52.20
40	5601-654	-	-	100	51.30
50	5601-655	-	-	100	51.30
60	5601-656	5602-156	-	100	49.50
80	5601-658	5602-158	-	100	48.60
100	5601-660	-	-	100	48.60
120	5601-662	5602-162	-	100	48.60
2" DIAMETER					
36	5601-703	5602-203	-	100	\$80.10
40	5601-704	5602-204	5602-704	100	77.40
50	5601-705	5602-205	-	100	74.70
60	5601-706	5602-206	-	100	72.90
80	5601-708	5602-208	-	100	72.00
100	5601-710	5602-210	-	100	70.20
120	5601-712	5602-212	5602-712	100	70.20
3" DIAMETER					
36	5601-803	5602-303	5602-803	50	\$50.85
40	5601-804	5602-304	-	50	49.50
50	5601-805	5602-305	-	50	48.15
60	5601-806	5602-306	-	50	46.80
80	5601-808	5602-308	-	50	45.45
100	5601-810	5602-310	-	50	44.10
120	5601-812	5602-312	-	50	44.10

ZirconiaPro 2 Ply Discs

Color: Green

Best Disc For: Rapid stock removal on Stainless Steel. Utilizes a Y weight cloth backing, with a fused Zirconium grain and lubricated super-size coating.

	TS-STYLE	TR-STYLE	TP-STYLE		
GRIT	ORDER NO.	ORDER NO.	ORDER NO.	PKG QTY	PRICE PER PKG
1-1/2" DIAMETER					
36	5604-653	5605-153	-	100	\$54.90
40	5604-654	5605-154	-	100	54.00
50	5604-655	5605-155	-	100	54.00
60	5604-656	5605-156	5605-656	100	52.20
80	5604-658	5605-158	5605-658	100	51.30
120	5604-662	5605-162	-	100	51.30
2" DIAMETER					
36	5604-703	5605-203	5605-703	100	\$84.60
40	5604-704	5605-204	-	100	81.00
50	5604-705	5605-205	-	100	79.20
60	5604-706	5605-206	5605-706	100	76.50
80	5604-708	5605-208	5605-708	100	75.60
120	5604-712	5605-212	-	100	74.70
3" DIAMETER					
36	5604-803	5605-303	5605-803	50	\$53.55
40	5604-804	5605-304	-	50	52.20
50	5604-805	5605-305	5605-805	50	50.85
60	5604-806	5605-306	5605-806	50	49.50
80	5604-808	5605-308	5605-808	50	48.60
120	5604-812	5605-312	-	50	47.70

Holder Pads

For All Quick Change Style Discs

Available for all small diameter Quick Change style discs, in soft, medium, and firm grades.



TS (SocAtt) TR (Lockit) TP (ClickOn)

			TS - TA4	TR - TA4	TP - TA4	
SIZE	DEN-SITY	MAX. RPM	ORDER NO.	ORDER NO.	ORDER NO.	PRICE EACH
3/4"	Med.	40,000	5641-014	-	-	\$ 8.61
1"	Med.	40,000	5641-015	-	-	8.20
1-1/2"	Soft	20,000	5641-016	5641-059	-	9.93
1-1/2"	Med.	25,000	5641-017	5641-060	5641-100	9.16
1-1/2"	Firm	30,000	5641-018	5641-061	-	10.29
2"	Soft	20,000	5641-019	5641-062	-	10.99
2"	Med.	25,000	5641-020	5641-063	5641-102	10.54
2"	Firm	30,000	5641-021	5641-064	-	12.57
3"	Soft	12,000	5641-022	5641-065	-	13.39
3"	Med.	20,000	5641-023	5641-066	5641-104	12.20
3"	Firm	20,000	5641-024	5641-067	-	14.53
5/8-11" ARBOR - LARGE DIAMETER, HARD FACE - TS HOLDER PADS						
4-1/2"	Med.	18,000	Low Profile		5641-160	28.70
4-1/2"	Med.	18,000			5641-150	28.70

Quick Change Discs

With 5/8-11 Hub

Incorporates a 5/8-11 metal TS hub for easy attachment to any pneumatic or electric right angle grinder with a 5/8-11 spindle. For use with large diameter holder pads, listed at the bottom of the Holder Pad chart. Max RPM: 10,000

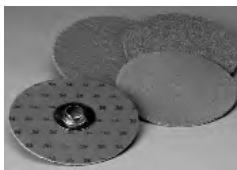

DIAM.	DESC.	GRIT	ORDER NO.	PRICE EACH
4-1/2"	A/O	36	5614-103	\$2.74
4-1/2"	A/O	60	5614-106	2.48
4-1/2"	A/O	80	5614-108	2.40
4-1/2"	ZirconiaPro	36	5614-113	3.54
4-1/2"	ZirconiaPro	60	5614-116	2.97
4-1/2"	ZirconiaPro	80	5614-118	2.88
4-1/2"	Ceramic Pro	36	5614-123	4.80
4-1/2"	Ceramic Pro	60	5614-126	3.64
4-1/2"	Ceramic Pro	80	5614-128	3.45

Flap Wheels

Perfect tool for deburring, blending, finishing and cleaning inside and outside diameters of ferrous and non-ferrous materials.

Mounted Flap Wheels (1"-3" Diameters)

Aluminum Oxide Resin Bond

* Permanently affixed 1/4" or 1/4-20 threaded steel shank allows choice of best system for your tooling, and fast wheel changes. Affixed mandrel for concentricity and reduced chatter; less operator fatigue.



			1/4" SHANK				1/4-20 SHANK					
			IMPORT		Weiber TIGER ABRASIVES		SA STANDARD ABRASIVES		Weiber TIGER ABRASIVES		SA STANDARD ABRASIVES	
SIZE	GRIT	STD. CTN.	ORDER NO.	PRICE	ORDER NO.	PRICE	ORDER NO.	PRICE	ORDER NO.	PRICE	ORDER NO.	PRICE
1" x 1"	60	10	5714-156	\$1.90	6552-003	\$3.23	5615-006	\$5.44	6552-601	\$3.23	5615-136	\$6.11
	80	10	5714-158	1.90	6552-004	3.23	5615-008	5.44	6552-603	3.23	5615-138	6.11
	120	10	5714-162	1.90	6552-005	3.23	5615-012	5.44	6552-605	3.23	5615-142	6.11
1-1/2" x 1"	60	10	5714-406	2.27	6552-009	4.01	5615-026	6.44	-	-	5615-156	7.14
	80	10	5714-408	2.27	6552-010	4.01	5615-028	6.44	-	-	5615-158	7.14
	120	10	5714-412	2.27	6552-011	4.01	5615-032	6.44	-	-	5615-162	7.14
2" x 1"	60	10	5714-556	2.69	6552-015	4.46	5615-056	8.15	6552-611	4.46	5615-186	8.24
	80	10	5714-558	2.69	6552-016	4.46	5615-058	8.15	6552-613	4.46	5615-188	8.24
	120	10	5714-562	2.69	6552-017	4.46	5615-062	8.15	6552-615	4.46	5615-192	8.96
2-1/2" x 1"	60	10	5714-706	3.25	6552-486	4.83	5615-076	9.81	-	-	5615-206	10.12
	80	10	5714-708	3.25	6552-487	4.83	5615-078	9.81	-	-	5615-208	10.12
	120	10	5714-712	3.25	6552-489	4.83	5615-082	9.81	-	-	5615-212	10.12
3" x 1"	60	10	5714-906	3.31	6552-027	6.46	5615-106	9.97	6552-621	6.46	5615-236	10.01
	80	10	5714-908	3.31	6552-028	6.46	5615-108	9.97	6552-623	6.46	5615-238	10.01
	120	10	5714-912	3.31	6552-029	6.46	5615-112	9.97	6552-625	6.46	5615-242	10.88



Mounted Flap Wheel Drive Arbor



THREAD SIZE	ADAPTED SIZE	ORDER NO.	PRICE EACH
1/4-20	1/4"	5642-100	\$2.40

Buff & Blend Combi Wheels

* Wheels are constructed with alternating flaps of Buff & Blend and coated abrasive material. High rate of cut, while providing a uniform scratch pattern.

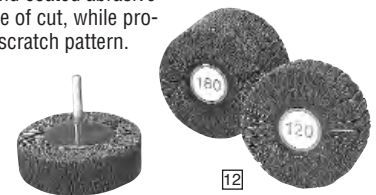

Large Flap Wheels (4"-6" Diameters)

Aluminum Oxide Resin Bond

* Best Flap Wheel for applications requiring high stock removal. Provides maximum stability and smaller contact areas on work surface. Highest initial cut rate.

			IMPORT		Weiber TIGER ABRASIVES		SA STANDARD ABRASIVES	
SIZE	GRIT	STD. CTN.	ORDER NO.	PRICE	ORDER NO.	PRICE	ORDER NO.	PRICE
4" x 1" x 5/8"	60	1	5716-156	\$ 9.00	6553-166	\$16.99	5615-526	\$19.51
	80	1	5716-158	9.20	6553-167	18.00	5615-528	20.66
	120	1	5716-162	9.85	6553-169	19.20	5615-532	22.07
6" x 1" x 1"	60	1	5716-356	17.45	6553-286	29.18	5615-546	28.81
	80	1	5716-358	17.80	6553-287	31.21	5615-548	30.32
	120	1	5716-362	18.70	6553-289	33.51	5615-552	32.83
6" x 2" x 1"	60	1	5716-456	26.25	6553-326	48.57	5615-576	47.51
	80	1	5716-458	26.85	6553-327	51.83	5615-578	50.54
	120	1	5716-462	28.85	6553-329	56.29	5615-582	61.34

			SA STANDARD ABRASIVES	
SIZE	GRIT	STD. CTN.	ORDER NO.	PRICE
2" x 1" x 1/4"	60	10	5650-788	\$ 11.77
	80	10	5650-789	11.77
	120	10	5650-790	11.77
	180	10	5650-791	11.77
3" x 1" x 1/4"	60	10	5650-792	14.29
	80	10	5650-793	14.29
	120	10	5650-794	14.29
3" x 2" x 1/4"	60	5	5650-796	21.23
	80	5	5650-797	21.23
	120	5	5650-798	21.23
	180	5	5650-799	21.23

Unmounted Flap Wheel Reducer Bushings

(Used in Pairs)



SIZE	ORDER NO.	PRICE/PAIR
1 to 1/2	6503-833	\$2.37
1 to 5/8	6503-834	2.37
1 to 3/4	6503-835	2.37

Unmounted Flap Wheel Spindle Adapters

SIZE	ORDER NO.	PRICE
1/4" Male (For 4" to 5" Wheels)	5642-120	\$20.41
3/8" Male (For 4" to 8" Wheels)	5642-122	20.41
5/8-11" Female (For 4" to 8" Wheels)	5642-124	20.41

Shop Rolls & Sanding Belts

Cloth Shop Rolls – Aluminum Oxide

* For Quick Stock Removal in Metal Finishing and Polishing Applications

* Ability to Tear Desired Amount Eliminates Waste

SIZE	GRIT	IMPORT		MADE IN USA		STANDARD ABRASIVES	
		ORDER NO.	PRICE	ORDER NO.	PRICE	ORDER NO.	PRICE
1"	50	-	-	-	-	5621-005	\$24.89
1"	60	5700-006	\$ 10.95	5700-306	\$22.80	5621-006	23.33
1"	80	5700-008	10.45	5700-308	21.80	5621-008	19.32
1"	100	5700-010	10.15	5700-310	21.20	5621-010	19.05
1"	120	5700-012	10.15	5700-312	21.20	5621-012	19.05
1"	150	5700-015	10.15	5700-315	21.20	5621-015	19.05
1"	180	5700-018	10.15	5700-318	21.20	5621-018	19.05
1"	220	5700-022	10.15	5700-322	21.20	-	-
1"	240	5700-024	10.15	5700-324	21.20	5621-024	19.05
1"	320	5700-032	10.15	5700-332	21.20	5621-032	19.05
1-1/2"	50	-	-	-	-	5621-105	34.76
1-1/2"	60	5700-106	15.70	5700-406	30.75	5621-106	32.84
1-1/2"	80	5700-108	14.95	5700-408	29.05	5621-108	27.09
1-1/2"	100	5700-110	14.65	5700-410	28.25	5621-110	26.09
1-1/2"	120	5700-112	14.65	5700-412	28.25	5621-112	26.09
1-1/2"	150	5700-115	14.65	5700-415	28.25	5621-115	26.09
1-1/2"	180	5700-118	14.65	5700-418	28.25	5621-118	26.09
1-1/2"	220	5700-122	14.65	5700-422	28.25	-	-
1-1/2"	240	5700-124	14.65	5700-424	28.25	5621-124	26.09
1-1/2"	320	5700-132	14.65	5700-432	28.25	5621-132	26.09
2"	50	-	-	-	-	5621-205	44.91
2"	60	5700-206	20.60	5700-506	39.75	5621-206	41.51
2"	80	5700-208	19.60	5700-508	36.80	5621-208	34.81
2"	100	5700-210	19.05	5700-510	34.35	5621-210	33.12
2"	120	5700-212	19.00	5700-512	34.35	5621-212	33.12
2"	150	5700-215	19.00	5700-515	34.35	5621-215	33.12
2"	180	5700-218	19.00	5700-518	34.35	5621-218	33.12
2"	220	5700-222	19.00	5700-522	34.35	-	-
2"	240	5700-224	19.00	5700-524	34.35	5621-224	33.12
2"	320	5700-232	19.00	5700-532	34.35	5621-232	33.12



Cloth Sanding Belts – Aluminum Oxide

GRIT	PKG QTY	1 x 42"		2 x 48"		3 x 21"		3 x 24"		4 x 24"	
		ORDER NO.	PRICE PER PKG	ORDER NO.	PRICE PER PKG	ORDER NO.	PRICE PER PKG	ORDER NO.	PRICE PER PKG	ORDER NO.	PRICE PER PKG
40	10	5701-754	\$10.55	5702-754	\$18.55	5703-754	\$14.95	5703-854	\$16.35	5704-604	\$22.55
50	10	5701-755	10.20	5702-755	18.00	5703-755	14.65	5703-855	16.10	5704-605	21.45
60	10	5701-756	9.70	5702-756	17.35	5703-756	14.20	5703-856	15.90	5704-606	21.05
80	10	5701-758	9.00	5702-758	15.25	5703-758	13.30	5703-858	15.40	5704-608	20.25
100	10	5701-760	8.65	5702-760	14.85	5703-760	12.35	5703-860	14.70	5704-610	19.55
120	10	5701-762	8.65	5702-762	14.85	5703-762	12.35	5703-862	14.70	5704-612	19.55
150	10	-	-	5702-765†	14.85	5703-765	12.35	5703-865	14.70	5704-615	19.55
180	10	-	-	5702-768†	14.85	5703-768	12.35	5703-868	14.70	5704-618	19.55



† Limited Quantities

* X-Weight

* Resin Bonded

* Heavy Duty Construction

* Ideal for sanding wood or metal

Other sizes and grits available upon request. Please inquire.

GRIT	PKG QTY	4 x 36"		6 x 48"	
		ORDER NO.	PRICE PER PKG	ORDER NO.	PRICE PER PKG
40	5	-	-	5705-654	\$32.55
50	5	5704-705	\$16.10	5705-655	31.15
60	5	5704-706	15.75	5705-656	30.45
80	5	5704-708	15.00	5705-658	28.45
100	5	5704-710	14.45	5705-660	27.50
120	5	5704-712	14.45	5705-662	27.50
150	5	5704-715	14.45	5705-665	27.50
180	5	5704-718	14.45	5705-668	27.50

Abrasive Sheets

Quality Import



Aluminum Oxide 9" x 11" Cloth Sheets

- Resin Bonded
- Ideal for Sanding Wood or Metal
- Outlasts Paper by as much as 5 Times

GRIT	STD PKG	ORDER NO.	PRICE PER PKG
50	50	3273-050	\$31.45
60	50	3273-060	30.15
80	50	3273-080	29.55
100	50	3273-100	27.95
120	50	3273-120	27.95
150	50	3273-150	27.95
180	50	3273-180	27.95
220	50	3273-220	27.95
240	50	3273-240	27.95
320	50	3273-320	27.95
400	50	3273-400	27.95

Emery 9" x 11" Cloth Sheets

- Resin Bonded
- Ideal for Metal Finishing where Polishing is more important than Stock Removal

GRIT	STD PKG	ORDER NO.	PRICE PER PKG
Coarse	50	3273-500	\$30.10
Medium	50	3273-510	28.00
Fine	50	3273-520	28.00

Crocus Cloth 9" x 11" Sheets

- Resin Bonded
- Flexible cloth backing
- Used by machinists & mechanics for smoothing metal surfaces

GRIT	STD PKG	ORDER NO.	PRICE PER PKG
Fine	50	3273-700	\$40.05

Silicon Carbide 9" x 11" Waterproof Sheets

- Latex Impregnated Paper
- Offers Versatility of Wet or Dry Sanding

GRIT	STD PKG	ORDER NO.	PRICE PER PKG
100	50	3273-600	\$22.60
120	50	3273-605	22.60
150	50	3273-610	19.40
180	50	3273-615	16.30
220	50	3273-620	16.30
240	50	3273-625	16.30
280	50	3273-630	16.30
320	50	3273-635	16.30
400	50	3273-640	16.30
500	50	3273-645	16.30
600	50	3273-650	16.30
800	50	3273-655	16.30
1000	50	3273-660	16.30
1200	50	3273-665	16.30

Silicon Carbide 9" x 11" Sandscreen Sheets

- Unique Screen Mesh Prevents Loading
- Will Outlast Ordinary Sandpaper by as much as 10 Times
- Use Wet or Dry on Metal or Wood

GRIT	STD PKG	ORDER NO.	PRICE PER PKG
80	25	5718-008	\$42.00
100	25	5718-010	37.80
120	25	5718-012	37.80
150	25	5718-015	37.80
180	25	5718-018	37.80
220	25	5718-022	37.80

Cartridge Rolls

Straight Cartridge Rolls

2

Aluminum Oxide Resin Bond Cartridge Rolls feature a multi-layer, multi-wear design for long lasting durability. New abrasive cutting points are exposed throughout the life of the roll. Use for flash removal, polishing, removing machine tool marks, edge breaking, etc.

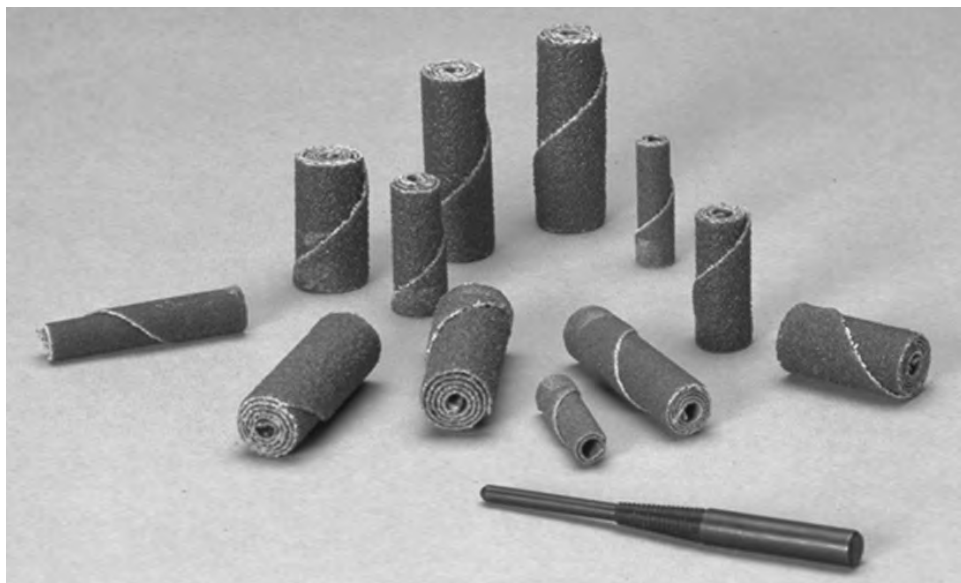

SIZE	GRIT	STD PKG	ORDER NO.	PRICE PER PKG
3/16 x 1 x 3/32	80	100	5618-001	\$24.45
3/16 x 1 x 3/32	100	100	5618-002	24.45
3/16 x 1 x 3/32	120	100	5618-003	25.27
3/16 x 1 x 3/32	150	100	5618-004	26.08
3/16 x 1 x 3/32	180	100	5618-005	26.08
3/16 x 1 x 3/32	240	100	5618-006	26.90
1/4 x 3/4 x 1/8	120	100	5618-007	26.08
1/4 x 1 x 1/8	60	100	5618-008	24.45
1/4 x 1 x 1/8	80	100	5618-009	24.45
1/4 x 1 x 1/8	100	100	5618-010	25.27
1/4 x 1 x 1/8	120	100	5618-011	25.27
1/4 x 1 x 1/8	180	100	5618-012	26.08
1/4 x 1 x 1/8	240	100	5618-013	26.90
1/4 x 1 x 1/8	320	100	5618-014	26.90
1/4 x 1-1/2 x 1/8	60	100	5618-015	29.34
1/4 x 1-1/2 x 1/8	80	100	5618-016	30.16
1/4 x 1-1/2 x 1/8	100	100	5618-017	30.97
1/4 x 1-1/2 x 1/8	120	100	5618-018	30.16
1/4 x 1-1/2 x 1/8	150	100	5618-019	31.79
1/4 x 1-1/2 x 1/8	180	100	5618-020	31.79
1/4 x 1-1/2 x 1/8	320	100	5618-021	32.60
1/4 x 1-1/2 x 1/8	400	100	5618-022	35.05
1/4 x 2 x 1/8	80	100	5618-023	39.12
1/4 x 2 x 1/8	100	100	5618-024	39.12
1/4 x 2 x 1/8	120	100	5618-025	39.94
5/16 x 1 x 1/8	60	100	5618-026	26.90
5/16 x 1 x 1/8	80	100	5618-027	27.71
5/16 x 1 x 1/8	120	100	5618-028	28.53
5/16 x 1-1/2 x 1/8	60	100	5618-029	35.05
5/16 x 1-1/2 x 1/8	80	100	5618-030	34.23
5/16 x 1-1/2 x 1/8	100	100	5618-031	36.68
5/16 x 1-1/2 x 1/8	120	100	5618-032	37.49
3/8 x 1 x 1/8	50	100	5618-033	26.90
3/8 x 1 x 1/8	60	100	5618-034	26.90
3/8 x 1 x 1/8	80	100	5618-035	27.71
3/8 x 1 x 1/8	100	100	5618-036	27.71
3/8 x 1 x 1/8	120	100	5618-037	27.71
3/8 x 1 x 1/8	180	100	5618-038	28.53
3/8 x 1 x 1/8	240	100	5618-039	29.34

SIZE	GRIT	STD PKG	ORDER NO.	PRICE PER PKG
3/8 x 1-1/2 x 1/8	40	100	5618-040	\$35.05
3/8 x 1-1/2 x 1/8	50	100	5618-041	35.05
3/8 x 1-1/2 x 1/8	60	100	5618-042	32.60
3/8 x 1-1/2 x 1/8	80	100	5618-043	34.23
3/8 x 1-1/2 x 1/8	100	100	5618-044	35.05
3/8 x 1-1/2 x 1/8	120	100	5618-045	34.23
3/8 x 1-1/2 x 1/8	150	100	5618-046	37.49
3/8 x 1-1/2 x 1/8	180	100	5618-047	37.49
3/8 x 1-1/2 x 1/8	240	100	5618-048	38.31
3/8 x 1-1/2 x 1/8	400	100	5618-049	39.94
3/8 x 2 x 1/8	60	100	5618-050	39.94
3/8 x 2 x 1/8	80	100	5618-051	40.75
3/8 x 2 x 1/8	100	100	5618-052	40.75
3/8 x 2 x 1/8	120	100	5618-053	41.57
1/2 x 1 x 1/8	50	100	5618-054	30.97
1/2 x 1 x 1/8	60	100	5618-055	30.16
1/2 x 1 x 1/8	80	100	5618-056	30.97
1/2 x 1 x 1/8	100	100	5618-057	31.79
1/2 x 1 x 1/8	120	100	5618-058	32.60
1/2 x 1 x 1/8	240	100	5618-059	34.23
1/2 x 1-1/2 x 1/8	36	100	5618-060	45.64
1/2 x 1-1/2 x 1/8	40	100	5618-061	44.01
1/2 x 1-1/2 x 1/8	50	100	5618-062	44.01
1/2 x 1-1/2 x 1/8	60	100	5618-063	42.38
1/2 x 1-1/2 x 1/8	80	100	5618-064	43.20
1/2 x 1-1/2 x 1/8	100	100	5618-065	44.01
1/2 x 1-1/2 x 1/8	120	100	5618-066	42.38
1/2 x 1-1/2 x 1/8	180	100	5618-067	45.64
1/2 x 1-1/2 x 1/8	240	100	5618-069	47.27
1/2 x 1-1/2 x 1/8	320	100	5618-070	47.27
1/2 x 2 x 1/8	60	50	5618-071	25.67
1/2 x 2 x 1/8	80	50	5618-072	26.08
1/2 x 2 x 1/8	100	50	5618-073	26.08
1/2 x 2 x 1/8	120	50	5618-074	26.49
1/2 x 2 x 3/16	60	50	5618-075	25.67
1/2 x 2 x 3/16	100	50	5618-077	26.08
1/2 x 2 x 1/4	40	50	5618-078	26.08

SIZE	GRIT	STD PKG	ORDER NO.	PRICE PER PKG
5/8 x 1 x 3/16	80	50	5618-079	\$24.86
5/8 x 1-1/2 x 1/8	80	50	5618-080	31.38
5/8 x 1-1/2 x 3/16	60	50	5618-081	30.56
5/8 x 1-1/2 x 3/16	80	50	5618-082	29.75
5/8 x 2 x 3/16	50	50	5618-084	35.05
5/8 x 2 x 3/16	60	50	5618-085	35.05
5/8 x 2 x 3/16	80	50	5618-086	37.49
5/8 x 2 x 3/16	100	50	5618-087	37.49
5/8 x 2-1/2 x 1/4	80	25	5618-088	28.53
3/4 x 1 x 1/8	80	50	5618-089	28.93
3/4 x 1 x 3/16	40	50	5618-090	27.71
3/4 x 1 x 3/16	80	50	5618-091	28.93
3/4 x 1-1/2 x 1/8	60	50	5618-092	35.45
3/4 x 1-1/2 x 1/8	80	50	5618-093	35.86
3/4 x 1-1/2 x 3/16	36	50	5618-094	35.86
3/4 x 1-1/2 x 3/16	60	50	5618-095	35.45
3/4 x 1-1/2 x 3/16	80	50	5618-096	35.05
3/4 x 1-1/2 x 3/16	120	50	5618-097	35.45
3/4 x 1-1/2 x 1/4	60	50	5618-098	35.45
3/4 x 1-1/2 x 1/4	80	50	5618-099	36.27
3/4 x 1-1/2 x 1/4	120	50	5618-100	37.08
3/4 x 2 x 1/8	100	25	5618-101	24.45
3/4 x 2 x 3/16	40	25	5618-102	22.62
3/4 x 2 x 3/16	60	25	5618-103	22.62
3/4 x 2 x 3/16	80	25	5618-104	23.64
3/4 x 2 x 3/16	100	25	5618-105	24.25
3/4 x 2 x 3/16	120	25	5618-106	23.64
3/4 x 2 x 1/4	60	25	5618-107	22.62
3/4 x 2 x 1/4	80	25	5618-108	24.45
3/4 x 2 x 1/4	100	25	5618-109	24.65
3/4 x 2 x 1/4	120	25	5618-110	24.65
1 x 1-1/2 x 1/4	60	25	5618-111	30.56
1 x 1-1/2 x 1/4	80	25	5618-112	31.38
1 x 2 x 1/4	60	25	5618-113	38.10
1 x 2 x 1/4	80	25	5618-114	39.32

Cartridge Rolls

Full Taper Cartridge Rolls

2

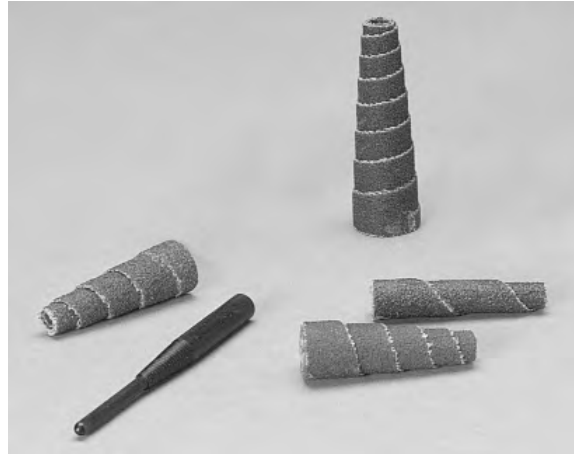

SIZE	GRIT	STD PKG	ORDER NO.	PRICE PER PKG
3/8 x 1 x 1/8	60	100	5618-300	\$50.53
3/8 x 1 x 1/8	80	100	5618-301	52.16
3/8 x 1 x 1/8	120	100	5618-302	52.98
3/8 x 1 x 1/8	180	100	5618-303	52.98
3/8 x 1-1/2 x 1/8	50	100	5618-304	50.53
3/8 x 1-1/2 x 1/8	60	100	5618-305	57.05
3/8 x 1-1/2 x 1/8	80	100	5618-306	54.61
3/8 x 1-1/2 x 1/8	120	100	5618-307	54.61

SIZE	GRIT	STD PKG	ORDER NO.	PRICE PER PKG
1/2 x 1 x 1/8	60	100	5618-308	\$53.79
1/2 x 1 x 1/8	80	100	5618-309	54.61
1/2 x 1 x 1/8	120	100	5618-310	57.05
1/2 x 1 x 1/8	180	100	5618-311	57.05
1/2 x 1-1/2 x 1/8	36	100	5618-312	61.94
1/2 x 1-1/2 x 1/8	50	100	5618-313	59.50
1/2 x 1-1/2 x 1/8	60	100	5618-314	58.68
1/2 x 1-1/2 x 1/8	80	100	5618-315	59.50
1/2 x 1-1/2 x 1/8	100	100	5618-316	61.13
1/2 x 1-1/2 x 1/8	120	100	5618-317	59.50
1/2 x 1-1/2 x 1/8	180	100	5618-318	61.94

SIZE	GRIT	STD PKG	ORDER NO.	PRICE PER PKG
1/2 x 2 x 1/8	60	50	5618-319	\$31.79
1/2 x 2 x 1/8	80	50	5618-320	32.60
1/2 x 2 x 1/8	180	50	5618-321	33.42
5/8 x 1 x 3/16	80	50	5618-322	33.42
5/8 x 2 x 1/4	100	50	5618-323	46.86
3/4 x 1-1/2 x 1/8	80	50	5618-324	41.57
3/4 x 1-1/2 x 3/16	50	50	5618-325	40.75
3/4 x 1-1/2 x 3/16	60	50	5618-326	40.75
3/4 x 1-1/2 x 3/16	80	50	5618-327	41.57
3/4 x 2 x 3/16	60	25	5618-328	23.43

Mandrels For Cartridge Rolls

2

- Cartridge Rolls of 3/4" length – 1/2" Pilot Length
- Cartridge Rolls of 1" length – 3/4" Pilot Length
- Cartridge Rolls of 1-1/2" length – 1" Pilot Length
- Cartridge Rolls of 2" length – 1-1/2" Pilot Length
- Cartridge Rolls of 2-1/2" length – 2" Pilot Length

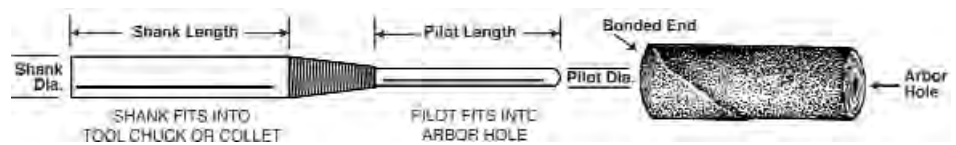

DESCRIPTION	PILOT DIA.	PILOT LGTH	SHANK DIA.	SHANK LGTH	O/A LGTH	ORDER NO.	PRICE EACH
CM-2B	3/32	3/4	1/8	1	2-3/4	5642-150	\$2.31
CM-2C	3/32	1	1/8	1	3	5642-151	2.31
CM-2E	3/32	3/4	1/4	1	2-3/4	5642-152	2.61
CM-2F	3/32	1	1/4	1-1/4	3	5642-153	2.61
CM-3	1/8	1/2	1/8	1	2-1/2	5642-154	2.31
CM-4	1/8	3/4	1/8	1	2-3/4	5642-155	2.31
CM-5	1/8	1	1/8	1	2-1/2	5642-156	2.31
CM-6	1/8	1-1/2	1/8	1	3-1/2	5642-157	2.61
CM-7	1/8	1/2	1/4	1-1/4	2-1/4	5642-158	2.61
CM-8	1/8	3/4	1/4	1-1/4	2-1/2	5642-159	2.61
CM-9	1/8	1	1/4	1-1/4	2-3/4	5642-160	2.23

DESCRIPTION	PILOT DIA.	PILOT LGTH	SHANK DIA.	SHANK LGTH	O/A LGTH	ORDER NO.	PRICE EACH
CM-10	1/8	1-1/2	1/4	1-1/4	3-1/4	5642-161	\$2.23
CM-11	1/8	2	1/4	1-1/4	4	5642-162	2.84
CM-15	3/16	3/4	1/4	1-1/4	2-1/2	5642-163	2.61
CM-16	3/16	1	1/4	1-1/4	2-1/2	5642-164	2.61
CM-17	3/16	1-1/2	1/4	1-1/4	3-3/8	5642-165	2.97
CM-18	3/16	2	1/4	1-1/4	4	5642-166	2.97
CM-20	1/4	3/4	1/4	1-1/4	2-3/4	5642-167	2.61
CM-21	1/4	1	1/4	1-1/4	3	5642-168	2.61
CM-22	1/4	1-1/2	1/4	1-1/4	3-1/2	5642-169	2.97
CM-23	1/4	2	1/4	1-1/4	4	5642-170	2.97

Surface Conditioning Discs ⁴ Quick Change Discs, Aluminum Oxide (A/O), FE

Type "FE" material is very flexible, with high edge durability. FE provides a high initial and extended rate of cut. Performs well on flat and contoured surfaces. Ideal on a variety of deburring, blending and cleaning applications.



SIZE	GRIT	MAX. RPM	TS-STYLE	TR-STYLE	TP-STYLE	HOOK & LOOP		PKG QTY	PRICE PER PKG
			ORDER NO.	ORDER NO.	ORDER NO.	MAX. RPM	ORDER NO.		
1"	Coarse	12,000 – 20,000	5650-103	5650-127	–	–	–	50	\$35.55
1"	Medium	12,000 – 20,000	5650-104	5650-128	–	–	–	50	35.55
1"	Very Fine	12,000 – 20,000	5650-105	5650-129	–	–	–	50	35.55
1-1/2"	Coarse	12,000 – 20,000	5650-106	5650-130	–	–	–	50	38.70
1-1/2"	Medium	12,000 – 20,000	5650-107	5650-131	–	–	–	50	38.70
1-1/2"	Very Fine	12,000 – 20,000	5650-108	5650-132	–	–	–	50	38.70
2"	Coarse	12,000 – 20,000	5650-109	5650-133	5650-163	–	–	50	56.25
2"	Medium	12,000 – 20,000	5650-110	5650-134	5650-164	–	–	50	56.25
2"	Very Fine	12,000 – 20,000	5650-111	5650-135	5650-165	–	–	50	56.25
3"	Coarse	10,000 – 18,000	5650-112	5650-136	5650-166	–	–	25	53.55
3"	Medium	10,000 – 18,000	5650-113	5650-137	5650-167	–	–	25	53.55
3"	Very Fine	10,000 – 18,000	5650-114	5650-138	5650-168	–	–	25	53.55
4-1/2"	Coarse	–	–	–	–	6,000 – 8,000	5650-256	10	28.44
4-1/2"	Medium	–	–	–	–	6,000 – 8,000	5650-257	10	25.02
4-1/2"	Very Fine	–	–	–	–	6,000 – 8,000	5650-258	10	25.02
5"	Coarse	–	–	–	–	5,000 – 7,000	5650-259	10	34.29
5"	Medium	–	–	–	–	5,000 – 7,000	5650-260	10	29.79
5"	Very Fine	–	–	–	–	5,000 – 7,000	5650-261	10	29.79
7"	Coarse	–	–	–	–	3,000 – 6,000	5650-262	10	58.50
7"	Medium	–	–	–	–	3,000 – 6,000	5650-263	10	52.38
7"	Very Fine	–	–	–	–	3,000 – 6,000	5650-264	10	52.38

Type "GP" Surface Conditioning Discs are also available upon request. Call for delivery. Not as flexible as Type "FE", works especially well on flat surfaces.

Holder Pads For All Quick Change Style Discs ²

Available for all small diameter Quick Change style discs, in soft, medium and firm grades.

SIZE	DENSITY	MAX. RPM	TS-STYLE	TR-STYLE	TP-STYLE	PRICE EACH
			w/TA4	w/TA4	w/TA4	
3/4"	Medium	40,000	5641-014	–	–	\$ 8.61
1"	Medium	40,000	5641-015	–	–	8.20
1-1/2"	Soft	20,000	5641-016	5641-059	–	9.93
1-1/2"	Medium	25,000	5641-017	5641-060	5641-100	9.16
1-1/2"	Firm	30,000	5641-018	5641-061	–	10.29
2"	Soft	20,000	5641-019	5641-062	–	10.99
2"	Medium	25,000	5641-020	5641-063	5641-102	10.54
2"	Firm	30,000	5641-021	5641-064	–	12.57
3"	Soft	12,000	5641-022	5641-065	–	13.39
3"	Medium	20,000	5641-023	5641-066	5641-104	12.20
3"	Firm	20,000	5641-024	5641-067	–	14.53

TS (SocAtt®)

TR (Lockit®)

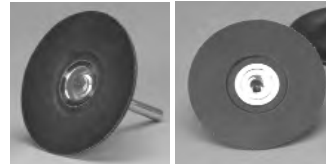

TP (ClickOn™)

Holder Pads For Hook & Loop Style Discs ²

SIZE	MAX. RPM	HOOK & LOOP		PRICE EACH
		MANDREL ORDER NO.	BUTTON STYLE* ORDER NO.	
4-1/2"	10,000	5642-502	5642-505	\$22.34
5"	10,000	5642-503	5642-506	22.34
7"	6,000	5642-504	–	26.24

* For Hook & Loop Style Discs with 5/8" nominal hole.

High Strength Buff & Blend Discs With Center Hole, Aluminum Oxide (A/O)

The best product for finishing and light deburring applications. A very conformable and durable tool for finishing and polishing applications on metals, plastics and glass.



⁴

SIZE	HOLE	GRADE	MAX. RPM	PKG QTY	ORDER NO.	PRICE PER PKG
5"	1/2"	Very Fine	4,000	10	5650-670	\$ 19.53
6"	1/2"	Very Fine	3,600	10	5650-671	24.66
7"	1/2"	Very Fine	3,000	10	5650-672	33.57
8"	1/2"	Very Fine	2,700	10	5650-673	40.59
10"	1/2"	Very Fine	2,000	10	5650-674	54.45
12"	1-1/4"	Very Fine	1,800	5	5650-675	36.18

Buff & Blend Discs ⁴

Buff & Blend Quick Change "GP" Discs, Aluminum Oxide (A/O)

Flexible, conformable discs constructed of GP material, which provides a high rate of cut while producing consistent finishes. Applications include blending, cleaning, deburring and finishing.

SIZE	GRIT	MAX. RPM	PKG QTY	TS-STYLE	TR-STYLE	PRICE PER PKG
				ORDER NO.	ORDER NO.	
1-1/2"	Medium	12,000	50	5650-506	5650-536	\$51.30
1-1/2"	Fine	12,000	50	5650-507	5650-537	49.95
1-1/2"	Very Fine	12,000	50	5650-508	5650-538	49.95
2"	Medium	12,000	50	5650-509	5650-539	55.80
2"	Fine	12,000	50	5650-510	5650-540	52.20
2"	Very Fine	12,000	50	5650-511	5650-541	52.20
3"	Medium	8,000	25	5650-512	5650-542	45.45
3"	Fine	8,000	25	5650-513	5650-543	41.18
3"	Very Fine	8,000	25	5650-514	5650-544	41.18



TS (SocAtt®)

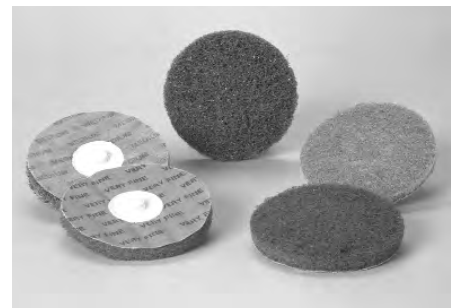

TR (Lockit®)

Non-Woven Abrasives

**Buy
Std. Ctn.
Deduct
10%***

**SA STANDARD
ABRASIVES**

*excluding accessories

Type 27 Unitized Discs

Manufactured from the highest quality Unitized material. Unique design offers material removal while imparting a final finish. Used in conjunction with, and sometimes in lieu of, a coated abrasive Resin Fibre Disc or Flap Disc.

- Deburring
- Edge Breaking
- Blending
- Cleaning
- Final Polishing

500	Soft Density - Finishing & Polishing
600	Medium Density - Blending & Polishing
700	Medium Density - Deburring & Cleaning
800	Hard Density - Deburring

12



SIZE	SERIES	STD. CTN.	ORDER NO.	PRICE PER PKG
4-1/2 x 7/8	532	5	5651-130	\$17.83
4-1/2 x 7/8	632	5	5651-131	19.48
4-1/2 x 7/8	732	5	5651-132	20.36
4-1/2 x 7/8	821	5	5651-135	23.23
4-1/2 x 7/8	811	5	5651-133	23.23

Surface Conditioning Flap Discs

**SA STANDARD
ABRASIVES**

Deburring, edge breaking, blending, cleaning, finishing, and polishing after traditional grinding is done with a Resin Fibre or Flap Disc on Steel, Stainless or Aluminum.

12

SIZE	GRADE	STD. CTN.	ORDER NO.	PRICE PER PKG
4-1/2 x 7/8	Coarse	5	5651-850	\$14.88
4-1/2 x 7/8	Medium	5	5651-852	14.88
4-1/2 x 7/8	Very Fine	5	5651-854	14.88



Quick Change Surface Conditioning Discs

Use on Die Grinders for deburring, blending, finishing, cleaning and polishing. Suitable for a wide variety of light fabrication, repair and for stainless steel, and ferrous & non-ferrous metals.

CGW

4

				CGW		
				ALUMINUM OXIDE		
DIAM.	GRIT	RPM	PKG. QTY.	ROLL ON (R HUB) ORDER NO.	TURN ON (S HUB) ORDER NO.	PRICE PER PACK
2"	Coarse	25,000	50	5723-300	5723-320	\$38.97
	Medium	25,000	50	5723-301	5723-321	38.97
	A Very Fine	25,000	50	5723-302	5723-322	36.92
3"	Coarse	20,000	25	5723-305	5723-325	36.41
	Medium	20,000	25	5723-306	5723-326	36.41
	A Very Fine	20,000	25	5723-307	5723-327	34.87



Roll On style, (R-Hub) shown

Convolute Wheels

Convolute Wheels are constructed by wrapping non-woven nylon, impregnated throughout with abrasive grain, around a hard core.

GP Plus Wheels

Removes medium to heavy burrs and edge breaking.

SIZE	GRAIN	SPEC.	GRADE	MAX. RPM	ORDER NO.	PRICE EACH
6 x 1/2 x 1	S/C	8SF	Fine	6,000	5651-880	\$ 44.23
6 x 1/2 x 1	S/C	8SM	Medium	6,000	5651-882	44.74
6 x 1/2 x 1	S/C	9SF	Fine	6,000	5651-881	44.23
6 x 1 x 1	S/C	8SF	Fine	6,000	5651-884	61.91
6 x 1 x 1	S/C	8SM	Medium	6,000	5651-887	62.64
6 x 1 x 1	S/C	9SF	Fine	6,000	5651-885	61.91
6 x 2 x 1	S/C	9SF	Fine	6,000	5651-888	110.26
8 x 1/2 x 3	S/C	8SF	Fine	4,500	5651-892	52.61
8 x 1/2 x 3	S/C	9SF	Fine	4,500	5651-893	52.61
8 x 1 x 3	S/C	8SF	Fine	4,500	5651-896	77.44
8 x 1 x 3	S/C	8SM	Medium	4,500	5651-894	78.31
8 x 1 x 3	S/C	9SF	Fine	4,500	5651-897	77.44
8 x 2 x 3	S/C	8SF	Fine	4,500	5651-900	135.02
8 x 2 x 3	S/C	8SM	Medium	4,500	5651-901	136.59
12 x 1/2 x 5	S/C	8SF	Fine	3,000	5651-904	74.23
12 x 1 x 5	S/C	8SF	Fine	3,000	5651-908	121.49
12 x 1 x 5	S/C	9SF	Fine	3,000	5651-909	121.49
12 x 2 x 5	S/C	8SF	Fine	3,000	5651-912	215.96
12 x 2 x 5	S/C	9SF	Fine	3,000	5651-913	215.96

LDW (Light Deburring Wheels)

Removes light burrs; use prior to polishing.

SIZE	GRAIN	SPEC.	GRADE	MAX. RPM	ORDER NO.	PRICE EACH
6 x 1/2 x 1	S/C	6SF	Fine	6,000	5651-920	\$ 44.86
6 x 1/2 x 1	S/C	7SF	Fine	6,000	5651-921	47.84
6 x 1/2 x 1	S/C	8SF	Fine	6,000	5651-922	47.84
6 x 1 x 1	S/C	6SF	Fine	6,000	5651-926	62.78
#6 x 1 x 1	S/C	7SF	Fine	6,000	5651-927	66.97
6 x 1 x 1	S/C	8SF	Fine	6,000	5651-928	66.97
8 x 1/2 x 3	S/C	8SF	Fine	4,500	5651-934	56.93
8 x 1 x 3	S/C	7SF	Fine	4,500	5651-939	83.78
8 x 1 x 3	S/C	8SF	Fine	4,500	5651-940	83.78
12 x 1/2 x 5	S/C	7SF	Fine	3,000	5651-945	73.60
12 x 1/2 x 5	S/C	8SF	Fine	3,000	5651-946	73.60
12 x 1 x 5	S/C	7SF	Fine	3,000	5651-951	120.44
12 x 1 x 5	S/C	8SF	Fine	3,000	5651-952	120.44
12 x 2 x 5	S/C	8SF	Fine	3,000	5651-958	214.10



Deburring Wheels

Excellent starting point for medium to heavy deburring and polishing.

SIZE	DENSITY	GRAIN	GRADE	MAX. RPM	ORDER NO.	PRICE EACH
6 x 1/2 x 1	Medium	S/C	Fine	6,000	5651-002	\$44.74
6 x 1/2 x 1	Hard	S/C	Fine	6,000	5651-003	44.74
6 x 1 x 1	Medium	S/C	Fine	6,000	5651-006	62.64
6 x 1 x 1	Hard	S/C	Fine	6,000	5651-007	62.64
6 x 2 x 1	Hard	S/C	Fine	6,000	5651-008	102.27
8 x 1/2 x 3	Hard	S/C	Fine	4,500	5651-010	53.23
8 x 1 x 3	Medium	S/C	Fine	4,500	5651-013	78.31
8 x 1 x 3	Hard	S/C	Fine	4,500	5651-014	78.31

Standard Abrasives – Unitized Mounted Points

Unitized Mounted Points are made from high durability material and are available in standard ANSI shapes for varying workpiece dimensions and applications.



Series:

600 – High Durability, Medium density (Blending/Polishing)

700 – High Durability, Medium density (Deburring/Cleaning)

800 – High Durability, Hard density (Deburring/Cleaning)

Size Chart:

A SHAPES							
SHAPE	MAX. RPM	SERIES	GRAIN	GRADE	PKG QTY	ORDER NO.	PRICE EACH
A21	34,500	631	A/O	Fine	5	5651-500	\$10.84
A21	34,500	632	S/C	Fine	5	5651-501	10.84
A21	34,500	731	A/O	Fine	5	5651-502	12.54
A21	34,500	732	S/C	Fine	5	5651-503	12.54
A21	34,500	811	A/O	Coarse	5	5651-504	12.65
A21	34,500	821	A/O	Medium	5	5651-505	12.65
A25	35,600	811	A/O	Coarse	5	5651-506	12.56
A25	35,600	821	A/O	Medium	5	5651-507	12.56

SHAPE	SIZE
A21	1" x 1" x 1/4"
A25	1" x 1" x 1/4"
B52	3/8" x 3/4" x 1/8"
B90	1/2" x 1/2" x 1/8"
B121	1/2" x 1/2" x 1/8"

SHAPE	SIZE
W160	1/4" x 1/4" x 1/8"
W163	1/4" x 1/2" x 1/8"
W183	1/2" x 1/4" x 1/8"
W185	1/2" x 1/2" x 1/8"
W220	1" x 1" x 1/4"

B SHAPES							
SHAPE	MAX. RPM	SERIES	GRAIN	GRADE	PKG QTY	ORDER NO.	PRICE EACH
B52	45,300	731	A/O	Fine	5	5651-508	\$5.09
B52	45,300	732	S/C	Fine	5	5651-509	5.09
B52	45,300	811	A/O	Coarse	5	5651-510	5.32
B52	45,300	821	A/O	Medium	5	5651-511	5.32
B90	34,500	731	A/O	Fine	5	5651-512	4.04
B90	34,500	732	S/C	Fine	5	5651-513	4.04
B90	34,500	811	A/O	Coarse	5	5651-514	4.60
B90	34,500	821	A/O	Medium	5	5651-515	4.60
B121	45,300	731	A/O	Fine	5	5651-516	4.41
B121	45,300	811	A/O	Coarse	5	5651-517	4.82
B121	45,300	821	A/O	Medium	5	5651-518	4.82

W SHAPES							
SHAPE	MAX. RPM	SERIES	GRAIN	GRADE	PKG QTY	ORDER NO.	PRICE EACH
W160	81,300	811	A/O	Coarse	5	5651-519	\$2.72
W160	81,300	821	A/O	Medium	5	5651-520	2.72
W163	60,000	811	A/O	Coarse	5	5651-521	3.20
W163	60,000	821	A/O	Medium	5	5651-522	3.20
W183	51,700	632	S/C	Fine	5	5651-523	3.08
W183	51,700	731	A/O	Fine	5	5651-524	3.20
W183	51,700	732	S/C	Fine	5	5651-525	3.22
W183	51,700	811	A/O	Coarse	5	5651-526	3.52
W183	51,700	821	A/O	Medium	5	5651-527	3.52
W185	34,500	631	A/O	Fine	5	5651-528	3.82
W185	34,500	632	S/C	Fine	5	5651-529	3.82
W185	34,500	731	A/O	Fine	5	5651-530	4.02
W185	34,500	732	S/C	Fine	5	5651-531	4.02
W185	34,500	811	A/O	Coarse	5	5651-532	4.46
W185	34,500	821	A/O	Medium	5	5651-533	4.46
W220	25,000	811	A/O	Coarse	5	5651-534	12.21
W220	25,000	821	A/O	Medium	5	5651-535	12.21

6" x 9" Hand Pads

Hand Pads are flexible, washable, and conform to workpiece. Ideal for hand applications on metals, composite or plastic surfaces. Use for cleaning, finishing or polishing. Color coded.



2

Hand Pad Holder ²

For use with 3" x 6" pads

Order No. 5642-520

Price each \$13.75

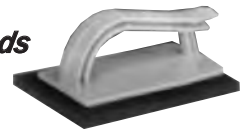

4

COLOR CODE	APPLICATION	IMPORT			TIGER			STANDARD ABRASIVES		
		ORDER NO.	PKG QTY	PRICE PER PKG	ORDER NO.	PKG QTY	PRICE PER PKG	ORDER NO.	PKG QTY	PRICE PER PKG
White	Non-Abrasive Pad <i>For Polishing and Light Cleaning</i>	5718-100	20	\$15.65	-	-	-	5651-700	60	\$59.91
Grey	Ultra-Fine S/C Abrasive Pad <i>For Free Hand Cleaning & Finishing</i> <i>Usable with mild detergents</i>	5718-105	20	15.65	6551-434	60	\$69.14	5651-705	60	58.90
Maroon	General Purpose A/O Abrasive Pad <i>For Basic Cleaning and Finishing</i> <i>Usable with most solvents</i>	5718-110	20	15.65	6551-444	60	69.14	5651-710	60	58.90
					Economy Grade					
					6551-460	60	52.16			
Tan	Heavy Duty A/O Abrasive Pad <i>For Heavy Duty Cleaning or Fast Action Finishing</i> <i>Usable with most solvents</i>	5718-120	10	20.80	6551-454	40	110.68	5651-720	40	98.80

Scouring Hand Pads

Green	Industrial	5718-115	20	15.65	-	-	-	5651-715	60	61.13
Green	Commercial (Food Processing)	-	-	-	6551-457	60	55.06	-	-	-